

# Ampco Centrifugal Pumps

DATA SHEET

MODEL KC2 2 1/2 X2

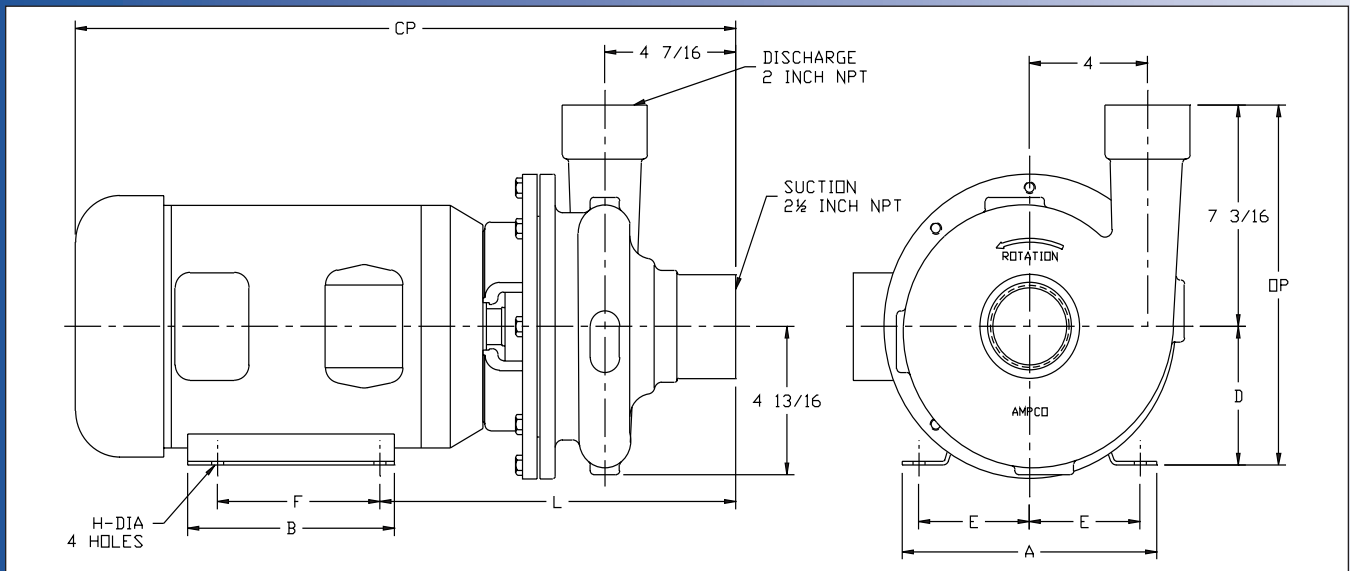

TEFC MOTOR			DIMENSIONS IN INCHES (For Reference Only)									APPROX. WEIGHT (LBS)
HP	RPM	FRAME	A (max)	B (max)	D	E	F	H	L	CP	OP	
1	1750	143JM	6-1/2	6	3-1/2	2-3/4	4	11/32	11-1/2	19-3/4	10-11/16	104
1-1/2	1750	145JM	6-1/2	6	3-1/2	2-3/4	5	11/32	11-1/2	19-3/4	10-11/16	108
2	1750	145JM	6-1/2	6	3-1/2	2-3/4	5	11/32	11-1/2	19-3/4	10-11/16	114
3	1750	182JM	8-5/8	6-1/2	4-1/2	3-3/4	4-1/2	13/32	12-1/8	21-1/8	11-11/16	140
5	3500	184JM	8-5/8	6-1/2	4-1/2	3-3/4	5-1/2	13/32	12-1/8	22-1/2	11-11/16	153
7-1/2	3500	213JM	9-5/8	8-1/8	5-1/4	4-1/4	5-1/2	13/32	13-1/8	25-3/8	12-7/16	121
10	3500	215JM	9-5/8	8-1/8	5-1/4	4-1/4	7	13/32	13-1/8	25-3/8	12-7/16	121
15	3500	215JM	9-5/8	8	5-1/4	4-1/4	7	13/32	13-1/8	25-1/4	12-7/16	263

## MATERIAL SPECIFICATIONS

PART NAME	NICKEL ALUMINUM BRONZE	STAINLESS STEEL
Casing, Impeller & Cover	AMPCO® 483	316 Stainless Steel
Shaft Sleeve & Impeller Screw	AMPCO® 18	316 Stainless Steel
Motor Shaft	Steel	Steel
Adapter	Cast Iron	Cast Iron

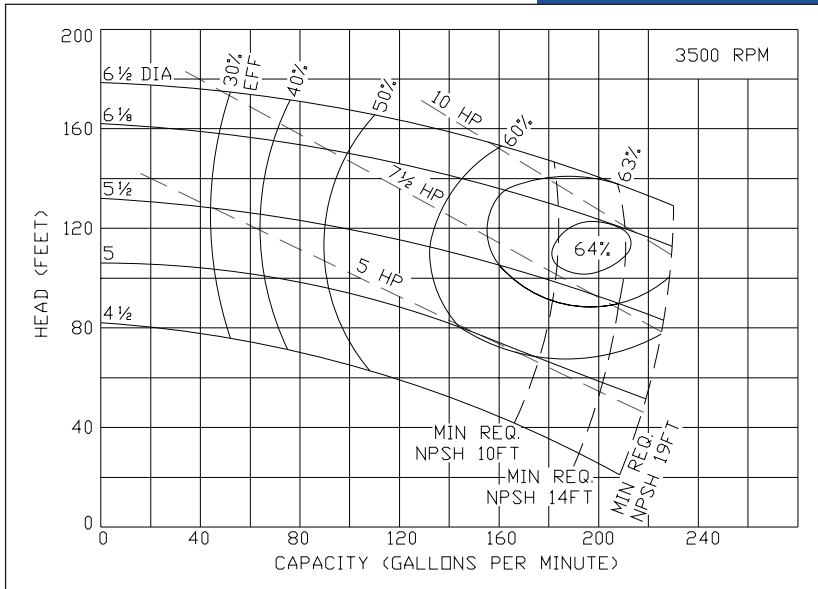

# Ampco Centrifugal Pumps

## MODEL KC2 2 1/2 X 2

Curves show approximate characteristics based on clear 68° water. Rated point is guaranteed.

Standard K Series pumps have threaded NPT connections. Models 1 1/2 x 1 1/4, 2 x 1 1/2 and 2 1/2 x 2 are mounted on JM frame motors and offer the same hydraulic performance as the comparable Z Series pump

Seal options include Type 21, Type 1 and Type 9 with choice of sealing materials.

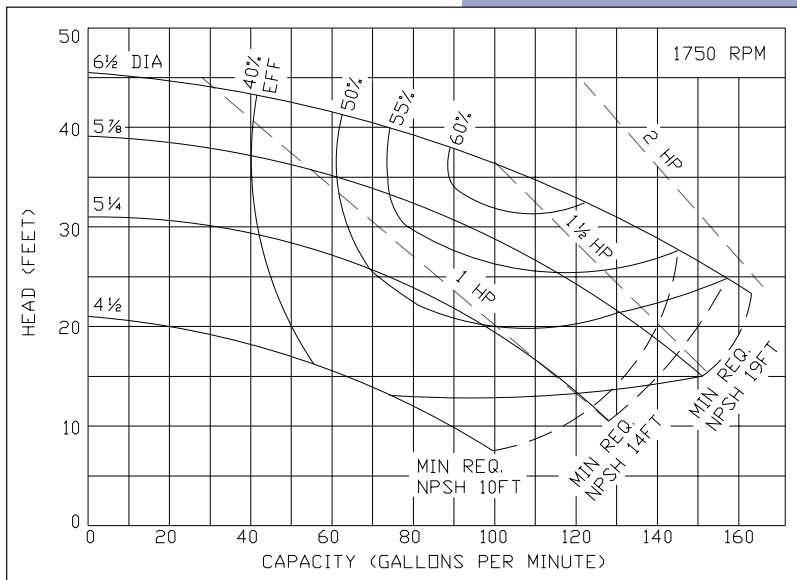
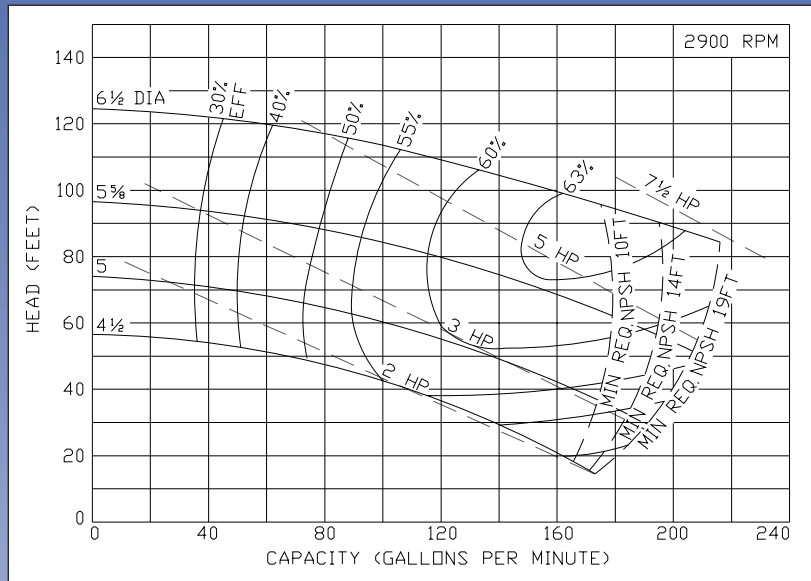

# Ampco Pumps Company

4424 West Mitchell Street  
 Milwaukee, Wisconsin 53214  
 PHONE (414) 643-1852  
 FAX (414) 643-4452