

## ZF PUMPS

1<sup>1</sup>/<sub>2</sub>x1<sup>1</sup>/<sub>4</sub>, 2x1<sup>1</sup>/<sub>2</sub>, 2<sup>1</sup>/<sub>2</sub>x2, 3x2<sup>1</sup>/<sub>2</sub>, 4x3

### AMPCO PUMPS COMPANY PARTS BREAKDOWN

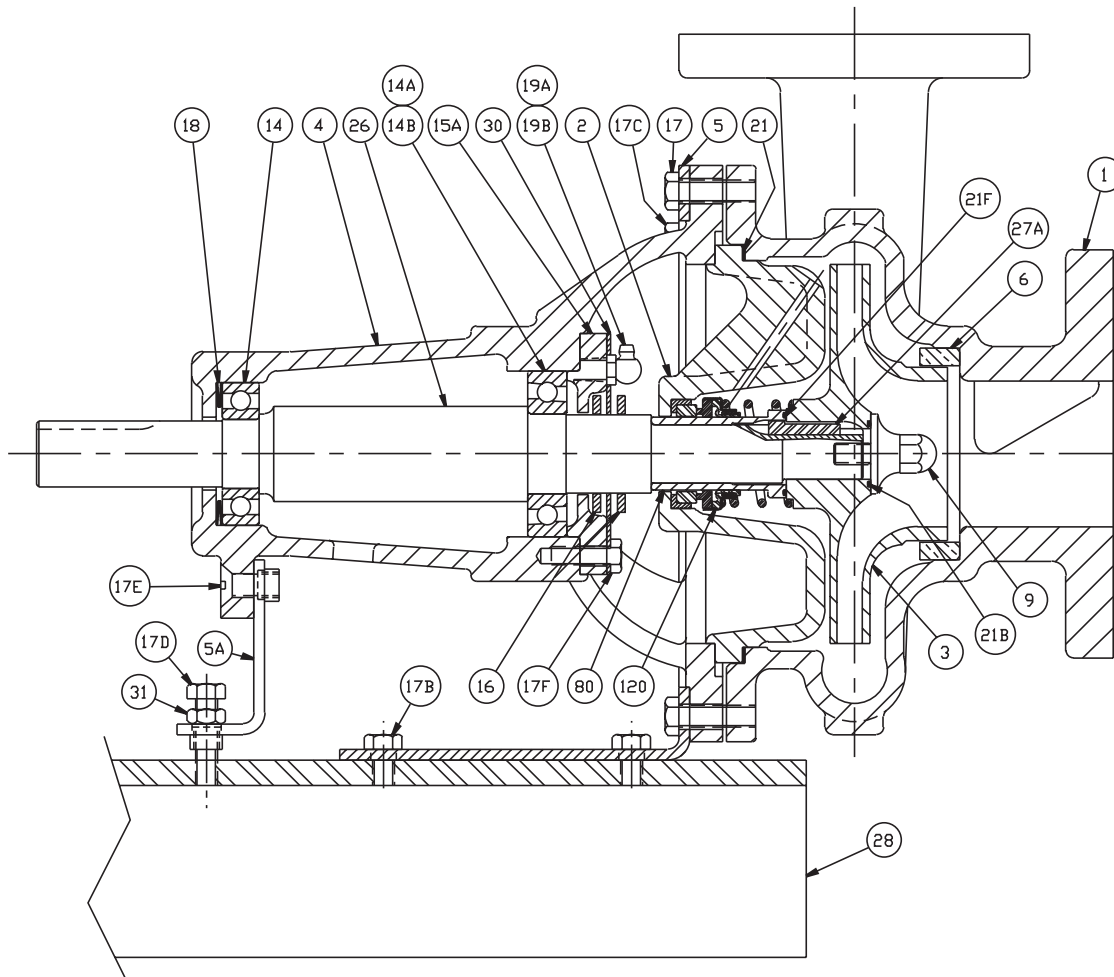

DETAIL NO.	REQ. NO.	PART NAME
120	1	MECHANICAL SEAL
80	1	SHAFT SLEEVE
31	3	LOCK NUT (REAR BRACKET LEVELING)
30	1	SPLASH PLATE
28	1	BASE
27A	1	IMPELLER KEY
26	1	SHAFT
21F	1	O-RING (SLEEVE/IMPELLER)
21B	1	GASKET OR O-RING (IMPELLER SCREW)
21	1	GASKET (CASING/COVER)
19B <sup>3</sup>	1	GREASE FITTINGS
19A <sup>1</sup>	1	PIPE PLUG
18	1	WAVE SPRING
17F	3	CAP SCREW (BEARING CAP)
17E	1	FLAT HEAD MACHINE SCREW
17D	3	CAP SCREW (REAR BRACKET LEVELING)
17C	2	CAP SCREW (FRONT BRACKET/FRAME)
17B	4	CAP SCREW (FRONT BRACKET/BASE)
17	8	CAP SCREW (CASING/FRAME)
16	2	SLINGER
15A	1	BEARING CAP
14B <sup>1,3</sup>	1	BALL BEARING-ANG. CONTACT-FRONT
14A	1	BALL BEARING-W/SEALS-FRONT
14	1	BALL BEARING-W/SEALS-REAR
9	1	IMPELLER SCREW
7 <sup>1,2</sup>	1	WEAR RING (COVER)
6	1	WEAR RING (SUCTION)
5A	1	BRACKET, REAR
5	1	BRACKET, FRONT
4	1	FRAME
3	1	IMPELLER
2	1	COVER
1	1	CASING

<sup>1</sup>NOT SHOWN

<sup>2</sup>ZF 4x3 ONLY

<sup>3</sup>14B AND 19B REPLACE 14A AND 19A ON  
ZF 3x2<sup>1</sup>/<sub>2</sub> AND 4x3 ONLY

NOTE: Please be sure to always include pump type, size, and serial number with any reference to above numbers and names.