

Zero **M**aintenance™ **Seals**

Products For Today's Budget and Today's Environment

Waterless Seals for Fristam® Pumps

Products using an advanced design and materials offer reliability and performance unmatched by any other seal.



*Single and Double
Seals Available
for 22mm, 30mm
& 35mm Shaft Sizes*

*Contact us at
zmtech@zmtech.com*

*See us at
www.zmtech.com*



2250 Stewart St. #6, Stockton, CA 95205 • (209) 547-1965 • FAX (209) 464-8140

www.zmtech.com

Better than OEM

Sealing Pumps

The New Way

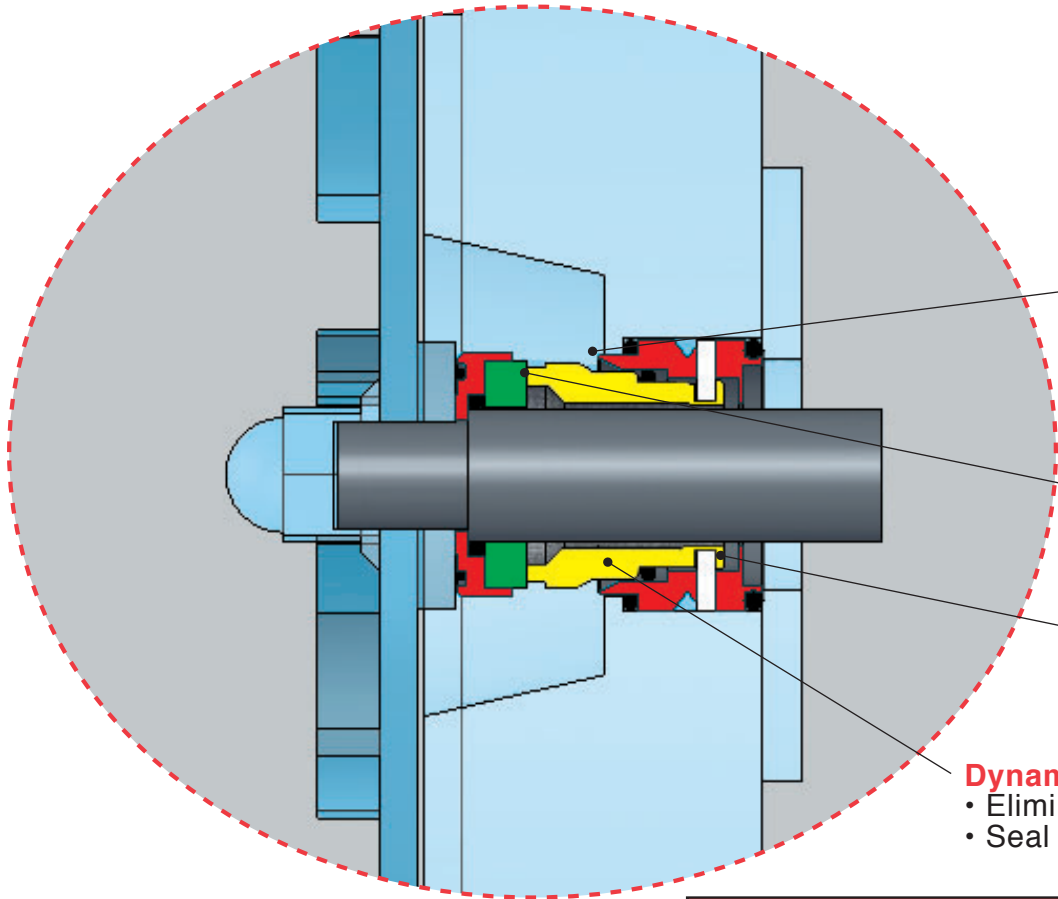

The Old Way

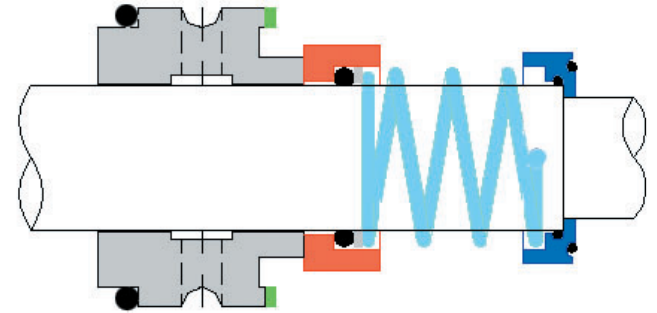

Design

- More sanitary because of Self-Cleaning taper
- Keeps cleaner during use, and self-cleans during CIP
- Fewer parts, easier installation
- Universal design – converts from single to double seal

Materials

- Better seal materials provides longer seal life
- No water flush needed, Silicon-Carbide faces is standard

Repairable

- Repair seal after use
- Seal Repair Kit saves money

Dynamic Stationary

- Eliminates shaft wear from O-ring
- Seal performs better with larger shaft run-out



(209) 547-1965
FAX (209) 464-8140

Fristam® OEM Seal	ZMT Fristam Seal	Benefits
Dynamic rotary	Dynamic stationary	Eliminates shaft wear
Spring in product	Spring removed from product	More sanitary
Throw seal away after use	Repair seal after use	Saves money
Seal may require water flush	Seal face materials is flushless	Saves water and wastewater
Separate single and double seal	Convertible design single to double	Saves inventory and money

Fristam® is a registered trademark of Fristam Pumps Inc.