

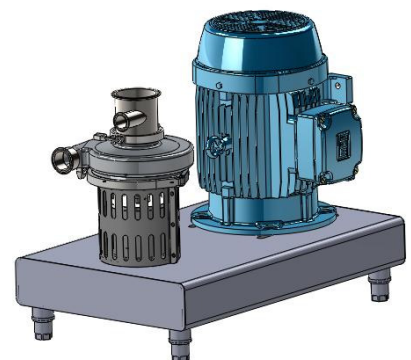

## AC+ Dry Blender

- Operation and Maintenance Manual
  - Models 2116, 2116 System, 3218, & 4329

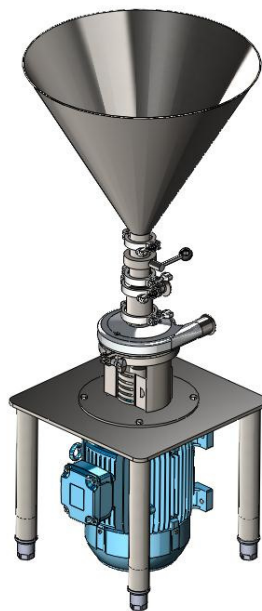
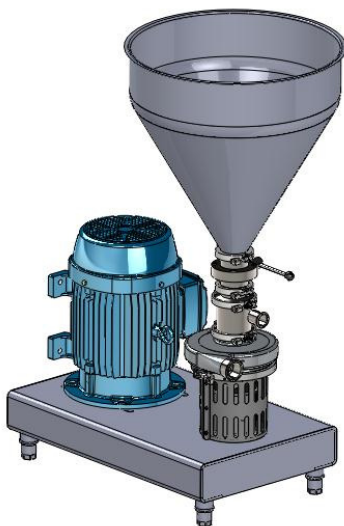

**Introduction/Warranty ..... 3**  
    Introduction ..... 3  
    General Information ..... 3  
    Shipping Damage or Loss ..... 3  
    Pump Receiving ..... 3

**Safety ..... 4**

**Operation ..... 6**  
    Installation ..... 6  
    Disassembly ..... 7  
        Models AC+2116 and AC+2116 System ..... 8  
        Models AC+3218 and AC+4329 ..... 9  
    Reassembly ..... 10  
        Models AC+2116 and AC+2116 System ..... 10  
        Models AC+3218 and AC+4329 ..... 11

**Maintenance ..... 12**  
    Maintenance ..... 12  
        Setting the Drive Collar ..... 13  
        Seal Replacement ..... 13

**Exploded View ..... 15**  
    AC+2116 ..... 15  
    AC+3218 ..... 17  
    AC+4329 ..... 19

**Troubleshooting ..... 21**

**Ampco Pumps Terms and Conditions ..... 23**

**Return Policy ..... 26**

### **Introduction**

To ensure the best results and service, please read and fully understand this manual prior to putting the unit into service. For any questions regarding operation or maintenance please contact your local distributor or Ampco Pumps Company:

*Ampco Pumps Company  
2045 W. Mill Road  
Glendale, WI 53209  
Phone: (800) 737-8671 or (414) 643-1852  
Fax: (414) 643-4452  
Email: [ampcocs@ampcopumps.com](mailto:ampcocs@ampcopumps.com)*

### **General Information**

Powder is introduced through the inner tube while the liquid flows through the outer tube to the mixing chamber. Because the liquid enters the chamber in the same direction as the impeller rotation, the flow is accelerated with minimal splashing. An inner screen creates back pressure, moving the liquid down and creating a natural suction into which the dry ingredient is introduced by opening the butterfly valve.

AC+ Dry Blenders are also suitable for liquid to liquid applications.

### **Shipping Damage or Loss**

Upon receiving equipment that is damaged or if your shipment is lost in transit, immediately file a claim with the carrier. At time of pick-up, the carrier signed the bill of lading, acknowledging that they have received the product from Ampco in good condition.

### **Pump Receiving**

When applicable, Ampco covers the pump inlet and discharge ports prior to shipping, ensuring that foreign matter does not enter the pump during shipment. If the protective covers are missing upon arrival, remove the pump cover and inspect to ensure it is free from contaminate before turning the shafts. Please make note of the serial number; this will assist in the process of ordering replacement parts and/or a warranty claim. For more information regarding shipment damage or warranty, please refer to the Introduction/Warranty section in this manual.

## Safety

**IMPORTANT:** ALWAYS WEAR SAFETY GLASSES WHEN OPERATING THIS UNIT. Read and understand this manual BEFORE installing, operating, or servicing this unit. Improper operation or maintenance may result in severe injury or death. Equipment damage caused by user neglect will invalidate the warranty.

Ampco Pumps Company advises users of our equipment to follow current Industrial Safety Standards. At the least, the following should be included:

- Occupational Safety and Health Administration (OSHA), Title 29 of CFR Section 1920.212
- General Requirements for all Machines
  - \* National Fire Protection Association, ANSI/NFPA 79
- Electrical Standards for Industrial Machinery
  - \* National Electrical Code, ANSI/NFPA 70
  - \* ANSI/NFPA 70 – National Electrical Code
  - \* ANSI/NFPA 70E – Electrical Safety Requirement for Employee Workplaces
- American National Standards Institute, Section B11

**Servicing electrically charged equipment can be dangerous.** It is recommended that industrial equipment be disconnected or locked out from the power source and stored energy, if present, be released. Refer to National Fire Protection Association Standards and OSHA rules for the Control of Hazardous Energy Sources and the Electrical Safety Related Work Practices.

Check for procedural requirements for lockout-tagout and personnel qualifications and training.

**Interconnected devices** should be checked to insure they are capable of performing their planned functions and are in proper working condition. These devices should be serviced according to the manufacturer's instructions.



It is recommended periodic inspections be made of the equipment with an initial inspection done within 3 to 4 months of installation, at minimum. Check the standards set by the National Electrical Manufacturers Association (NEMA) for inspection of the electrical control system and for setting up a scheduled maintenance and inspection program.

**DO NOT ATTEMPT TO MODIFY AMPCO PUMPS COMPANY BLENDERS.** Your altering the product may give rise to unsafe conditions and result in harm to you or others. Altering the product voids Ampco Pumps warranty on the blender. Ampco blenders should only be used where general product service ratings apply.

## Safety

## Ampco Pumps Company

This manual uses the following warnings and cautions to help you avoid injury or possible equipment damage.

	Indicates a hazardous situation is imminent that <i>will</i> result in death or serious injury if not avoided.
	Marked with a warning triangle to indicate that hazards or unsafe practices, if not avoided, could result in severe injury or death. Also used to warn against unsafe functioning or maintenance practices.
	Marked with a warning triangle to indicate that hazards or unsafe practices, if not avoided, could result in death or injury or product or property damage.

All Ampco blenders have safety labels. Do not remove any labels from any Ampco Pumps product.

---

**Installation**

It is important that the AC+ Dry Blender be installed within 3 feet (1 meter) of the liquid source. The supply piping should be short with a minimum number of elbows and fittings that impact flow of the liquid into the blending chamber. An eccentric reducer is recommended at the liquid inlet of the blender. The need for future cleaning and inspection should be considered when installing the blender.

A supply pump is required to feed the liquid to the blender. A discharge pump may also be required for certain applications. Contact Ampco Pumps for supply and discharge pump recommendations.

The adjustable legs should be installed to the base of the unit and the blender should be positioned where the blending operation will take place. Use a wrench to adjust the legs, one at a time, until the unit is level.

Connect the supply and discharge piping, making sure each is positioned correctly and properly supported. Incorrect piping may result in strain on the blender casing. The AC+2116 model has an 1 ½ inch (38.1mm) liquid inlet, 2 inch (50.8mm) powder inlet, and 1 ½ inch (38.1mm) liquid outlet. The AC+3218 model has 1 ½ inch (38.1mm) liquid inlet, 3 inch (76.2mm) powder inlet, and 2 inch (50.8mm) liquid outlet. The AC+4329 model has a 2 inch (50.8mm) liquid inlet, 4 inch (101.6 mm) powder inlet, and 3 inch (76.2 mm) liquid outlet.

The purchaser is responsible for supplying and installing all piping. Liquid inlet piping should be short and provide a direct route into the blender. There should be a minimum number of elbows and fittings in the supply piping. Elbows in the liquid inlet piping will produce increased friction in the line which will result in cavitation in the blender casing. Cavitation will result in vibration, noise, poor performance, and possible damage to the blender. It is recommended the pipe diameter at the inlet be increased in size where possible. Using an eccentric tapered reducer in place of a concentric reducer at the inlet will help direct the flow to minimize turbulence.

It is possible to order the blender with an electrically controlled Butterfly valve. The electric valve should be wired to an auxiliary 110V power source. This will allow the valve to operate separately from the blender motor so it may be closed if the motor fails. If the power source to the Butterfly valve also fails, it should be possible to manually override the valve by applying a wrench to the flats on the coupling adapter.

## Disassembly

To prevent malfunctions as a result of worn or broken parts, it is recommended the blender be inspected periodically. The following are procedures for disassembling the AC+2116, AC+3218, and the AC+4329 models.

There are three types of seals available for the AC+ Dry Blender: D, DG, and E Double Seal. The following steps remain the same throughout the three seal types:

1. Disconnect the blender from the liquid inlet piping (suction) and the discharge piping.
2. Loosen the nut on the clamp securing the hopper to the blender until the tension on the clamp is relieved.
3. Remove the clamp, hopper, and gasket.
4. Loosen the clamp holding the control valve.
5. Hold the valve while removing the clamp to prevent it from falling. To repair the valve, see manufacturer's instructions.
6. Loosen and remove the clamp at the top of the inlet adapter.
7. Remove the clamp, the diffuser, and the suction tube.
8. Loosen and remove the clamp securing the inlet tube adapter to the casing.
9. Remove the adapter and the gasket.
10. Remove the large clamp that secures the casing to the back plate.
11. Using both hands, firmly pull the casing straight up and away from the back plate.
12. Remove the screen from inside the casing.
13. Using the appropriate wrench, remove the nut and gasket that secure the impeller to the stub shaft.
14. Remove the impeller.

From this point forward, disassembly varies according to the type of seal in the blender. Refer to the instructions for your specific seal arrangement.

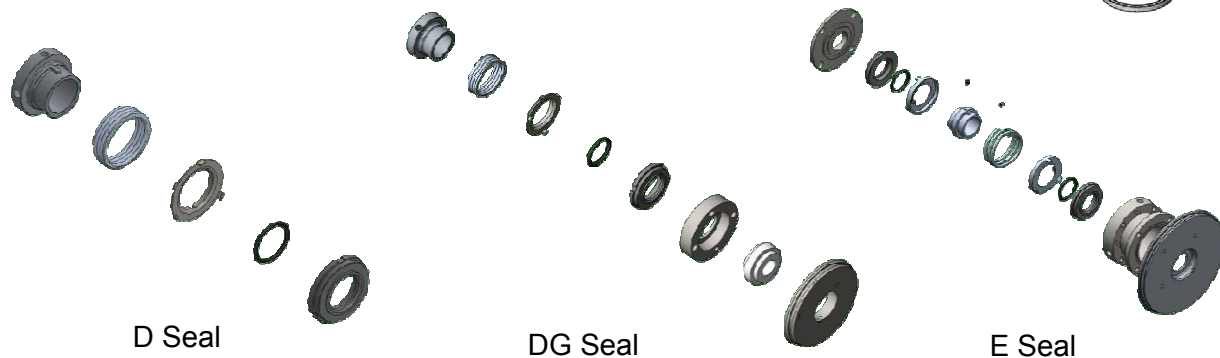
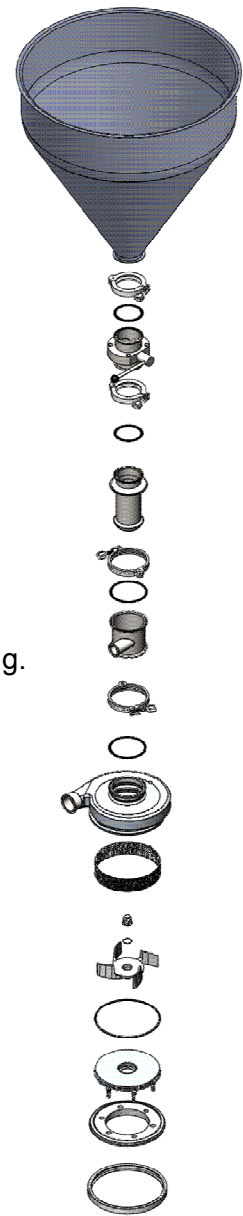

1. Carefully remove the back plate and inspect the back plate, the gasket, and the casing for scratches, nicks, or wear.
2. For models with the DG seal, remove four screws from the back plate. Inspect the DG seal insert, gland ring, and gaskets. Replace parts showing any wear or damage. Caution should be used in handling the back plate. Avoid damage to the back plate surface around the carbon seal opening.
3. Remove the carbon seal, cup, spring, and o-ring seal from the stub shaft.
4. Remove the drive collar from the shaft.

For E Seal replacement/reassembly, see page 13

5. Disconnect the inlet and outlet for the water to the stuffing.
6. Four screws hold the follower to the stuffing box. Remove all four screws.
7. Carefully slide the back plate assembly with the stuffing box off the shaft.
8. From the shaft, remove the inboard carbon seal, the cup, the seal spring, and the seal o-ring.
9. Loosen the two set screws and remove the drive collar.
10. From the stub shaft, remove the carbon seal, cup, seal o-ring, and the follower.

**Please note, special attention should be made to drive collar replacement, as incorrect setting on the DG seal may allow for excessive wear on the seal**

### Models AC+2116 and AC+2116 System

1. To remove the drive motor from the AC+2116 or AC+2116 System, place a block suitable in size under the motor. Turn the adjustable legs until the motor rests on the block.
2. Remove the seal guard.
3. Remove the carbon seal, cup, spring, and o-ring from the stub shaft.
4. Loosen the set screws and remove the drive collar.
5. The deflector should be removed by lifting it straight up and off.
6. Use the appropriate wrench to remove the four nuts, bolts, and lock washers that secure the motor to the base.
7. The motor should now rest on the block. Lift the base from the motor. The stub shaft should remain attached to the motor.
8. Loosen the socket head cap screw in the shaft collar and slide the collar off.
9. Use a flat bar to pry beneath the stub shaft and remove it from the motor shaft.
10. Check the stub shaft for nicks or scratches that may cause o-ring seal wear and leaking.
11. To remove the adapter ring and spacers, set the base on its side and hold the adapter ring while removing the six socket head screws in the bottom of the base.
12. Remove the legs from the base.
13. Inspect all blender o-rings for damage and replace as needed.

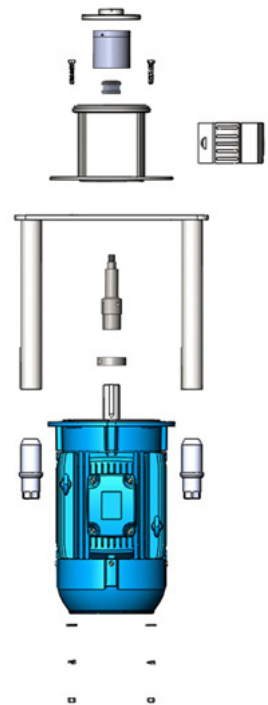



## Disassembly

### Models AC+3218 and AC+4329

Models AC+3218 and AC+4329 are operated by a pulley system located on the underside of the base. To remove drive components the entire blender and base must be tipped on its side. The motor end should be toward the floor. The hopper, valve, inlet tubing, casing, impeller, seal guard, and seal components should all be removed before tipping the unit on its side.

1. On the top of the base, loosen the mounting bolts that secure the drive to the base. The base is slotted so the motor may be slid toward the blender.
2. Remove the drive belts.
3. Remove the bolts that secure the blender pulley to the underside of the base.
4. Use those same bolts and tighten into the forcing holes. Finger tighten.
5. Using the appropriate wrench, tighten the bolt until the pulley releases from the bushing. Remove the bolt and the pulley.
6. Remove the tapered bushing from the shaft of the blender.
7. To remove the adapter ring and spacers, hold the adapter ring to prevent it from falling while you remove the six cap screws.
8. Set the blender back down on all four legs.
9. Loosen the bearing housing from the base by removing the cap screws .
10. Grasp the bearing housing with both hands and firmly lift it off the blender base.
11. Remove the retaining ring.
12. Press the shaft from the housing. Use the appropriate puller to remove the bearings from the shaft then remove the second bearing from the housing.
13. Check the stub shaft for nicks or scratches.
14. All components should be checked for cracks or wear. Check o-rings for damage. Inspect the legs for worn threads. Worn or damaged components should be replaced.

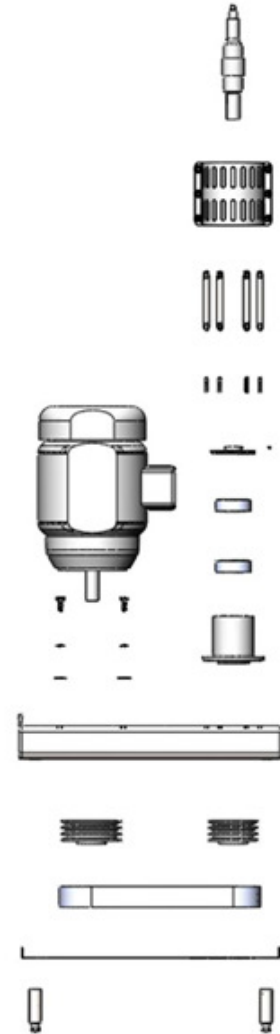

Bearings are sealed and have lifetime lubrication. Worn or damaged bearings should be replaced with identical bearings and be replaced as a set.

---

**Reassembly****Models AC+2116 and AC+2116 System**

1. Screw the adjustable legs into the base. On the 2116 System, use bolts to attach the base to the dolly.
2. Mount the six spacers and the ring adapter to the base. Place the base on the top of the motor. Mount the motor.
3. Loosely set the four motor mounting screws. Enough movement must be allowed to allow alignment of the motor shaft in the back plate.
4. Slide the stub shaft down and over the motor shaft.
5. Place the casing gasket on the back plate. Slide the back plate over the stub shaft.
6. Place the impeller on the shaft. There should be approximately 1/16" clearance between the back plate and impeller. The caps crews on the shaft collar may now be tightened securely.
7. Remove the impeller and check the position of the stub shaft. If the stub shaft is not centered in the back plate, move the motor until the stub shaft is centered. Securely tighten the motor mount screws.
8. Install the balanced seal. Sealing of the process fluid along the shaft is accomplished by action of the process pressure on an o-ring seal installed in a groove in the carbon seal. The same action pressurizes the o-ring groove and augments the spring tension in keeping a tight joint at the sealing faces. The width of the seal face controls the balancing of the seal. This type of seal should be replaced when the clearance between the carbon seal face and the back plate is less than 1/32: (0.79mm) or when leakage is noted. \*\*See instructions for setting the drive collar and seal replacement on page 13\*\*
9. Again place the impeller back gasket and impeller on the stub shaft. Place the impeller nut gasket on the impeller nut. Secure the impeller by tightening the impeller nut.
10. Place the screen to the notch on the inside of the casing. Check to see the screen fits snugly and does not spin.
11. Set the casing on the back plate and clamp together with the large casing clamp.
12. Install the seal guard.
13. Install the inlet tube assembly with gaskets and clamps. Tighten clamps. Note: there is a top and bottom to the inlet tube assembly. Place the assembly to be opposite the casing outlet tube.
14. Install the diffuser and suction tube with the gaskets and clamps. Tighten securely.
15. Mount the control valve with gaskets and clamps. Tighten.
16. Mount the hopper to the top of the valve with gaskets and clamps. Tighten.
17. Connect supply and discharge piping.

## Reassembly

### Models AC+3218 and AC+4329

1. Place the o-ring into the deflector collar.
2. From the bottom, slide one bearing onto the shaft until it rests against the shoulder. The AC+4329 model requires two bearings at the shoulder of the shaft.
3. Place the shaft in the bearing housing.
4. The other bearing should be installed on the shaft through the bottom of the bearing housing.
5. Place the retaining ring on the bottom of the shaft.
6. The bearing housing should then be installed by placing it on top of the base and tightening the bolts.
7. Place the deflector at the top of the bearing housing.
8. The retainer ring and spacers are set by first screwing the six spacers into the ring then bolting the spacers onto the base plate.
9. If your blender has the DG seal, install the seal gland ring with gaskets and attach to the back plate before installing the back plate.
10. Slide the back plate over the shaft, being careful to not damage the sealing surface. Place the back plate onto the retainer ring.
11. Center the shaft by tightening the spacer bolts in a cross pattern. Once the shaft is centered, remove the back plate.
12. To install the motor, the blender must be tipped back on its side. Tighten the motors bolts so they touch the bottom of the base and can be used to adjust the tension on the belts.
13. To install the pulley system, start with the blender pulley, installing the pulley key, pulley, and bushing. Tighten the bolts.
14. Next install the motor end of the pulley system. Install the motor pulley key, the pulley, and the bushing. Tighten the bolts. Both pulleys should be aligned horizontally.
15. Use the mounting bolts to draw the motor pulley tight. Tighten the bolts a small amount at a time, alternating between the three, until all are tight.
16. Now you need to install the drive belts onto both the motor and the blender pulley. You may need to move the motor to do this. The plate that holds the motor to the top of the base has slots with bolts that can be loosened to allow for this movement.
17. Once the drive belts are on the pulleys, move the motor back and away from the blender until there is a deflection of 5/16" (7.9mm) when applying 5 to 7 pounds of force to the belt.
18. Secure the motor and set the blender back on all four legs.
19. Install the seal. See the instructions for setting the drive collar and seal replacement.
20. Place the casing gasket on the back plate and install the back plate on the shaft.
21. Install the impeller by tightening it down with the impeller nut, making sure the impeller nut gasket is included.
22. Place the screen to the notch on the inside of the casing. Check to see the screen fits snugly and does not spin.
23. Firmly place the casing on the back plate and use the casing clamp to secure.
24. Install the seal guard below the casing.
25. Place the inlet adapter above the casing. Secure the adapter to the casing with the clamp and gasket.
26. Add the diffuser and suction tube assembly to the top of the inlet adapter. Secure with the clamp and gasket.
27. Install the butterfly valve if supplied with the blender.
28. Install the hopper to the top of the butterfly valve and secure it with a gasket and clamp.

# Maintenance

# Ampco Pumps Company

The AC+ Dry Blender requires normal cleaning and inspection to insure its best performance. The blender is relatively maintenance free but Ampco Pumps Company recommends periodic inspection of seals and seal faces. Worn or damaged parts that may include cuts or abrasions to seals or nicks or cracks to seal faces, should be replaced upon detection. In order to clean and sanitize the blender, it is necessary to disassemble all the parts to the AC+ except for the drive motor.

1. Disconnect the liquid supply piping and the discharge piping from the blender.
2. Remove the clamp securing the hopper to the AC+ Dry Blender. \*\*The AC+4329 is normally *not* ordered with a hopper and valve. If that is the case with your blender, skip to step 5.
3. Remove the clamp connecting the end connections of the Butterfly valve.
4. Refer to valve manual for disassembling the valve.
5. Remove the clamps and blender tubes, beginning at the top and working towards the bottom. Continue until you reach the casing.
6. Remove the clamp that secures the casing to the back plate. Use both hands to firmly grasp the casing, pulling it up and off the back plate. \*\*A gasket separates the casing and back plate. Do not use a tool to try and pry them apart. This could damage the surfaces of the adapter ring and the gasket. Firmly tugging the casing should separate the casing from the back plate.
7. Remove the screen inside the casing.
8. Remove the impeller and back plate. Protect the sealing surface of the back plate against all nicks and scratches when removing for cleaning and disassembly.
9. Rinse all disassembled parts with lukewarm water (approximately 100° F) until all traces of product are removed.
10. Clean all the components with an all-purpose, powdered alkaline cleaner, following manufacturer's recommendations.
11. Immediately rinse with lukewarm water until all of the cleaning agent has been removed.
12. Rinse with hot water.
13. Place components so they will drain and air dry.
14. Inspect o-rings and replace if necessary.
15. Before reassembling, spray gaskets with a sanitary lubricant.
16. If any damaged or worn parts are noticed during cleaning, replace them before reassembling the unit.
17. Reverse the order of disassembly to reassemble the blender.

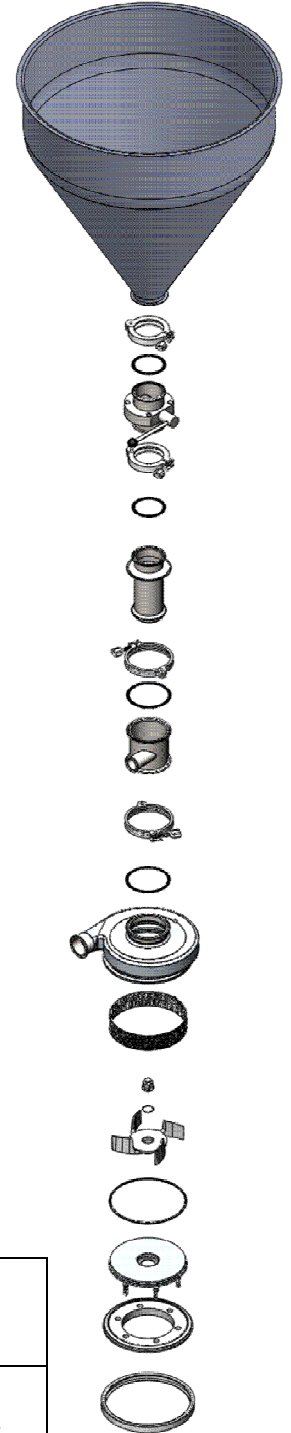

	<p style="text-align: center;"><b>WARNING</b></p> <p>Relieve pressure and remove all fluid from blender prior to disassembly</p>
	<p style="text-align: center;"><b>WARNING</b></p> <p>Turn off electrical power supply and Lock Out before servicing or maintenance. Use a locking device for which only the person doing the work has the key.</p>

## Setting the Drive Collar and Seal Replacement

### Blenders with D or DG Seals

To replace the seal, assemble the spring, seal cup, o-ring seal, and carbon seal. Install as a unit, taking care that the slot in the seal cup is aligned with the pin on the drive collar. Gentle finger pressure will overcome o-ring resistance on the shaft.

When the carbon seal is replaced, the location of the drive collar should be checked and relocated if necessary. Use one of the two following methods.

#### Set the Drive Collar by Measurement

1. Install the back plate, gasket, and casing.
2. Install and tighten the casing clamp.
3. Behind the back plate, mark the correct location of the drive collar by scribing a line on the shaft. See Figures 1-3 where point A is  $11/32"$  ( $0.87\text{mm}$ )
4. Remove the casing clamp, casing, and back plate.
5. Place the drive collar on the shaft, setting it in relation to the scribe mark and tighten set screws.
6. Install the seal spring, cup, seal o-ring, and carbon seal onto the shaft.

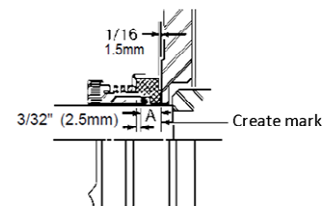

Figure 1: D Seals

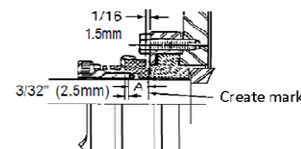

Figure 2: DG Seals

#### Set the Drive Collar by Position

1. Set the spring, cup, o-ring seal, and carbon seal on the drive collar. Check that the spring does not rest on the tab that is bent back. A portion of the spring is offset to provide clearance for this tab. Care must be taken to ensure that the pin on the drive collar is in line with the slot on the cup.
2. Install the spring, cup, o-ring, and carbon seal as a unit onto the shaft.
3. Install the back plate and casing.
4. Clamp the casing to the back plate and tighten the clamp.
5. To locate the drive collar position, slide the collar and seal assembly towards the back plate until the o-ring and carbon seal are pushed tight against the back plate.
6. Slide the drive collar back from the back plate by  $1/32"$  ( $0.79\text{mm}$ ). Tighten the set screws to secure the drive in this location.
7. Install the seal spring, cup, seal o-ring and carbon seal onto the shaft.
8. For DG seals, set the DG insert and gaskets into the gland ring and screw the gland ring to the back plate.

NOTE: Extra care should be taken when assembling AC+ Blenders with type DG seals. Incorrect stub shaft settings will allow the impeller hub to contact the inboard face of the stationary seal seat. Interference of the impeller hub and seal seat face will cause wear of impeller hub and damage to the inboard or secondary seal face of the clamped-in seat. Visual inspection is recommended after installation of the impeller and before installation of the casing to ensure clearance between the impeller hub and seal face. If no clearance is visible, the blender should be disassembled and the stub shaft moved forward to provide at least  $1/32"$  ( $.79\text{mm}$ ) clearance between the impeller hub and seal seat face. Reset seal drive collar if necessary.

If the drive collar is properly positioned and seal components are properly installed, the shaft should rotate freely by hand. If excessive effort is required to rotate the shaft, check to be sure that all components are properly installed and the drive collar is properly installed.

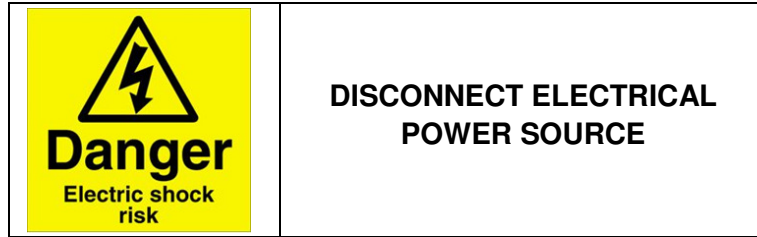

**TYPE E WATER COOLED BALANCED DOUBLE SEAL**

1. Install the back plate, gasket, and casing.
2. Secure the casing to the back plate with the clamp and gasket.
3. To mark the location of the drive collar, scribe a line on the shaft.
4. Remove the casing clamp, casing, and back plate.
5. Place the follower, one carbon seal, one seal oring, one cup, and the drive collar on the shaft.
6. Set the drive collar to the scribe mark shown in Figure 3 and secure it to the shaft by tightening the set screws.

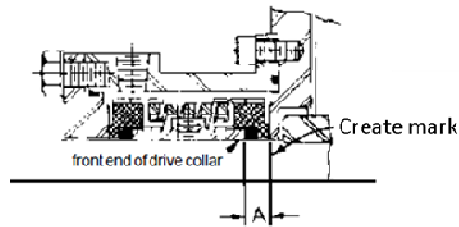

Figure 3: E Seals

7. Install the remaining seal components, including the seal spring, cup, seal o-ring, and carbon onto the shaft. Take care that the slot in the seal cup is aligned with the pin on the drive collar. Gentle finger pressure will overcome o-ring resistance on the shaft.
8. Place the stuffing box and back plate assembly over the stub shaft and the seal components.
9. Next set the follower onto the stuffing box and secure it by tightening the four screws.
10. Assemble the seal guard and tighten the nut.
11. Attach the water inlet and outlet to the stuffing box.

After setting the drive collar and assembling the seal, return the Reassembly (page 10) for final steps.

# Exploded View

# Ampco Pumps Company

## Parts List: AC+2116

Key	Description	Part Number	Qty	Key	Description	Part Number	Qty
1	Hopper	DBH2116-2-TC	1	15	Casing Gasket	S216-90A-U	1
2	(2") Clamp	13MHHM200	2	18	Casing Clamp	S216-75AR-S	1
3	(2") Gasket	40MP-U200	2	19	Deflector/Slinger	DBX8207351	1
4	(2") Butterfly Valve	B5101E200CC-C	1	20	Impeller Key	S216-95C-316L	1
5	Diffuser/Dry Feed Tube	DBX2116-200D	1	21	Stub shaft	C216E-18TP-06	1
6	(2.5") Clamp	13MHHM250	2	22	Shaft Collar Screw	GX5494026SS	1
7	(2.5") Gasket	40MP-U250	2	23	Shaft Collar	SX18000014	1
8	Inlet Adapter	DBX2116-250W	1	24	Adapter Cap Screw	(D) GX5079700 (DG) SC1710H-SS (E) SC1106E-SS	4
9	Pump Casing	S316DB-01C-E	1	25	Seal Guard	C216-18T-131-S	1
10	Casing Screen	DBX8307982	1	27	Adapter	216D18T-71DB-SS	1
11	Impeller Nut	S216-91C-316L	1	28	Platform/Base	DBB2116-180	1
12	Impeller Nut Gasket	S216-25A-U	1			DBB2116-210	
13	Impeller	S216-02DB-316L	1	29	Motor	Optional	1
14	Impeller Back Gasket	S216-25B-U	1	30	O-Ring, Rotor Hub	N70224	1

D1	Carbon Seal	216E-80-1A	1 (D)	E1	Carbon Seal	216E-80-1A	2
D2	Seal O-Ring	01-1165-19-U	1	E2	Seal O-Ring	01-1165-19-E	2
D3	Cup D	216D-80-3P	1	E3	Cup E	216E-80-3P	2
D4	Spring D	216D-80-4	1	E4	Drive Collar E	216E-23-316L	1
D5	Drive Collar D	SP216D-23P-S	1	E5	Spring E	216E-80-4A	1
D6	Set Screws	SC1105A-SS	3	E6	Set Screws	SC1103A-SS	3
D7	Back plate D	(D) 216D-11-316 (DG) SP216G-11-316L	1	E7	Stuffing Box	216E-83B-316	
D8	Gasket -Thick	SP216G-80-12AG	1	E8	Back plate E	216E-11B-316	1
D9	Seal Seat	SP216G-80-11SC	1	E9	Follower	216E-17-316	1
D10	Gasket -Thin	SP216G-80-12G	1	E10	Lock washer	LWA-1300-SS	4
D11	Gland Ring	SP216G-17-316L	1	E11	Machine Screw	SC1308H-SS	4
D12	Mounting Bolt	GX5076004	4	E12	O-RING	17-122-U	1
D13	Lock Washer	LWA-1300-SS	4	E13	O-Ring	17-275-U	1
D14	Set screw cup point	GX5494026SS	3				

# Exploded View

# Ampco Pumps Company

Figure 4: AC+2116

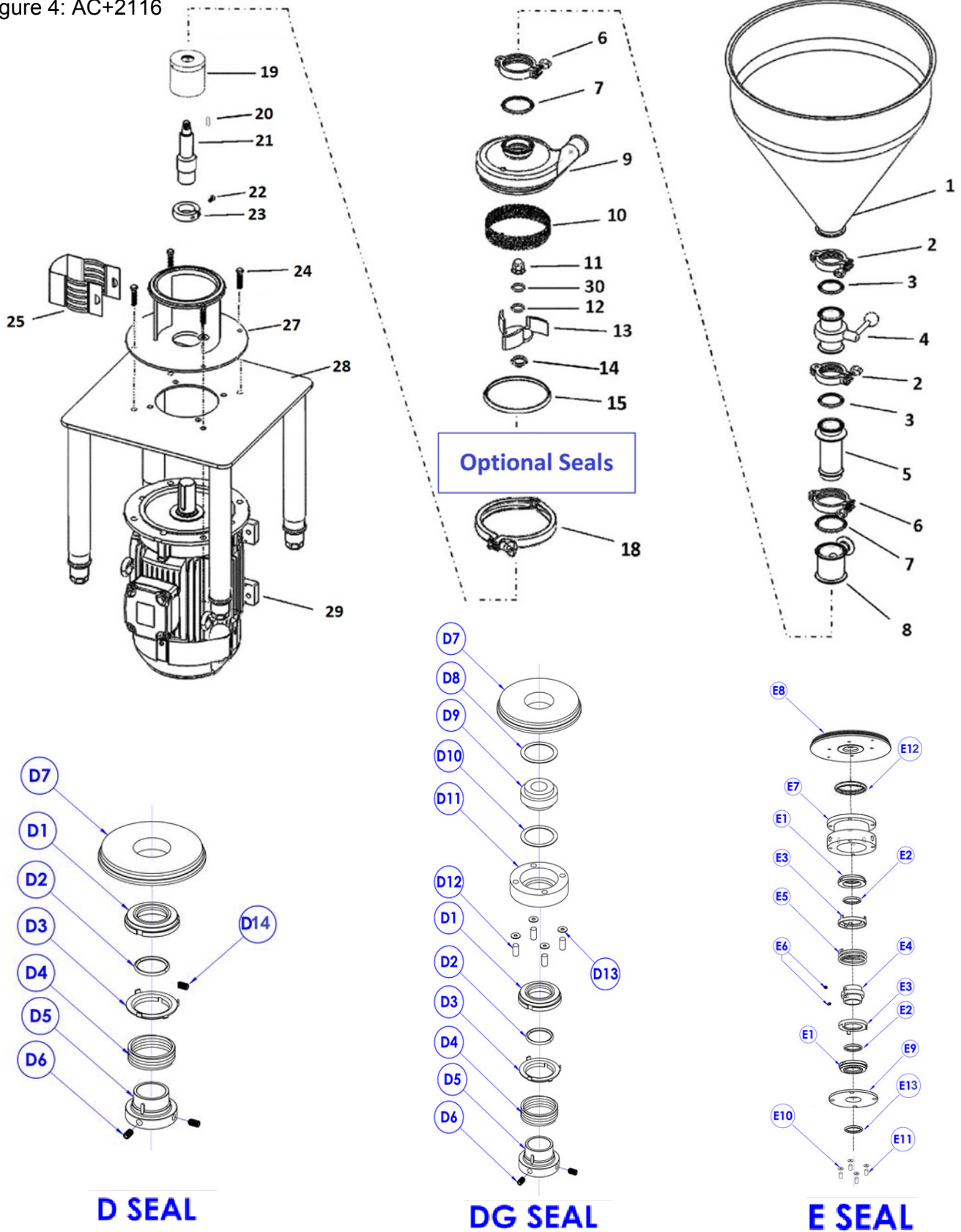



# Exploded View

# Ampco Pumps Company

## Parts List: AC+3218

Key	Description	Part Number	Qty	Key	Description	Part Number	Qty
1	Hopper	DBH3218-3-TC	1	23	Hex Cap Screw	GX5503110	6
2	3" Clamp	13MHMM300	2	24	Flat Washer	P1GX43-189	12
3	Gasket	40MPF-U300	2	25	O-Ring Rotor Nut	N70130	1
4	Butterfly Valve	B5101E300CC-C	1	26	Support Column	DBX8112312	6
5	Diffuser/Suction Tube	DBX3218-300D	1	28	Retaining/Snap Ring	99142A685	1
6	4" Clamp	13MHMM400	2	30	Bearing	DBX5212-2RS	2
7	Gasket	40MPF-U400	2	31	Bearing Frame	DBX8307752	1
8	Inlet Adapter	DBX3218-400W	1	32	Blender Base	DBB3218-250	1
9	Pump Casing	S428DB-01C-E	1			DBB3218-280	
10	Screen	DBX8307762	1			DBB3218-320	
11	Impeller Nut	S328-91C-316L	1	33	Motor	Optional	1
12	Impeller Nut Gasket	S328-25A-U	1	35	Socket Cap Screw	GX5503115S	6
13	Impeller	S328-02DB-316L	1	36	Sheave Dodge 1	455627	1
14	Casing Gasket	S328-90A-U	1	37	Sheave Dodge 2	455621	1
15	Impeller Back Gasket	S328-25B-U	1	38	Hex Nuts	GX5503000	6
16	Deflector/Slinger	(D) DBX8207082 (E) DBX8207702	1	39	Flat Washer	GX10610500	4
17	Hex Cap Screw	GX5077200	6	40	Adapter Cap screw	GX5079700	4
18	Pump Adapter	DBX8307742	1	41	Belt	7888K222 (1750) 7888K252 (1450)	1
19	Adapter Casing Clamp	S328-75AR-S	1	42	SD Sheave Bushing	120382	1
20	Impeller Key	S328-95C-316L	1	43	SK Sheave Bushing	120431	1
21	Stub shaft	C328E-25DB-06	1	44	Flat Washer	GX5505015	6
22	Guard	DBX8307732	2	45	Lock washer	GX5503010	6

D1	Carbon Seal	328E-80-1A	1	E1	Carbon Seal	328E-80-1A	2
D2	Seal O-Ring	S328-80-2-U	1	E2	Seal O-Ring	328E-80-1A	2
D3	Cup D	328D-80-3P	1	E3	Cup E	328E-80-3P	2
D4	Spring D	328D-80-4	1	E4	Drive Collar E	328E-23-316L	1
D5	Drive Collar D	SP328D-23P-S	1	E5	Spring E	328E-80-4A	1
D6	Set Screws	SC1105A-SS	2	E6	Set Screws	SC1103A-SS	2
D7	Back plate D	(D) 328D-11-316 (DG) SP328G-11-316L	1	E7	Stuffing Box	DBX8207712	1
D8	Gasket -Thick	SP328G-80-12AG	1	E8	Back plate E	328E-11B-316	1
D9	Seal Seat	SP328G-80-11SC	1	E9	Follower	DBX8207722	1
D10	Gasket -Thin	SP328G-80-12G	1	E10	Lock washer	LWA-1300-SS	4
D11	Gland Ring	SP328G-17-316L	1	E11	Machine Screw	SC1308E-SS	4
D12	Mounting Bolt	SC1310H-SS	4	E12	O-Ring	17-274-U	1
D13	Lock Washer	LWA-1300-SS	4	E13	O-Ring	17-153-U	1

# Exploded View

# Ampco Pumps Company

Figure 5: AC+3218

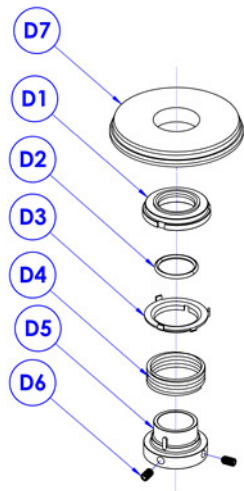
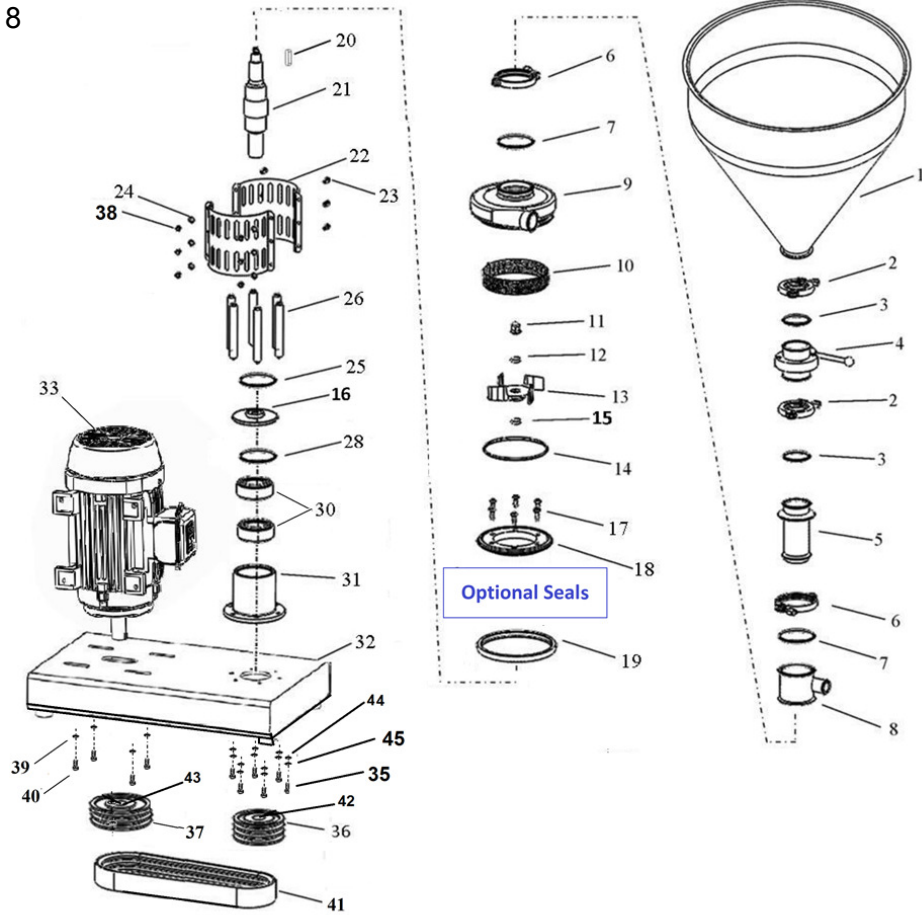

**D SEAL**

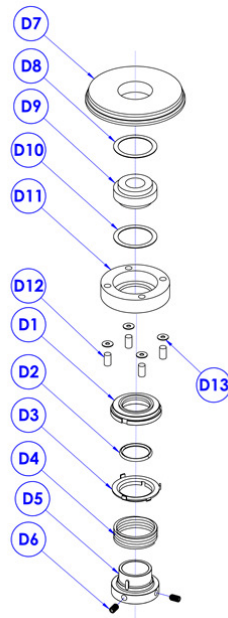

**DG SEAL**

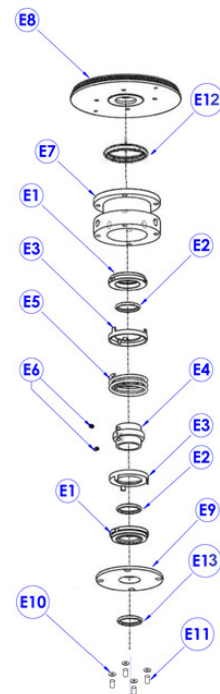

**E SEAL**

# Exploded View

# Ampco Pumps Company

## Parts List: AC+4329

Key	Description	Part Number	Qty	Key	Description	Part Number	Qty
1	Hopper	DBH4329-4-TC	1	22	Guard	DBX8207292	2
		DBH4329-36-4-TC		23	Hex Cap Screw	GX5503110	6
2	6" Clamp	13MHHM600	2	24	Flat Washer	P1GX43-189	12
3	Gasket	40MPF-U600	2	25	O-Ring Rotor Nut	N70130	1
4	Butterfly Valve	B5101E400CC-C	1	26	Support Column	DBX8112462	6
5	Diffuser/Suction Tube	DBX4329-400D	1	28	Retaining/Snap Ring	99142A685	1
6	4" Clamp	13MHHM400	2	30	Bearing	DBX5212-2RS	2
7	Gasket	40MPF-U400	2	31	Bearing Frame	DBX8307752	1
8	Inlet Adapter	DBX4329-600W	1	32	Blender Base	DBB3218-280	1
9	Pump Casing	SP6410DB-01C-E	1			DBB3218-320	
10	Screen	DBX8308112	1	33	Motor	Optional	1
11	Impeller Nut	S4410-91C-316L	1	35	Socket Cap Screw	GX5503115S	6
12	Impeller Nut Gasket	S4410-25A-U	1	36	Sheave Dodge 1	455621	1
13	Impeller	S4410-02DB-316L	1	37	Sheave Dodge 2	455627	1
14	Casing Gasket	SP4410-90A-U	1	38	Hex Nuts	GX5503000	6
15	Impeller Back Gasket	S4410-25B-U	1	39	Thick Flat Washer	GX10610500	4
16	Deflector/Slinger	(D) DBX8207082 (DG) DBX8207331 (E) DBX8207702	1	40	Adapter Cap Screw	GX5079700	4
17	Cap Screw	GX5077200	6	41	Belt	7888K252	1
18	Pump Adapter	DBX8308231	1	42	SD Sheave Bushing	120382	1
19	Adapter Casing Clamp	SP4410-75D-S	1	43	SK Sheave Bushing	120435	1
20	Impeller Key	S4410-95C-316L	1	44	Flat Washer	GX5503015	6
21	Stub Shaft	4410E-25DB-06	1	45	Lock Washer	GX5503010	6

D1	Carbon Seal	4410E-80-1	1	E1	Carbon Seal	4410E-80-1	2
D2	Seal O-Ring	17-15-U	1	E2	Seal O-Ring	17-15-U	2
D3	Cup D	4410D-80-3	1	E3	Cup E	4410E-80-3	2
D4	Spring D	4410D-80-4	1	E4	Drive Collar E	4410E-23-316	1
D5	Drive Collar D	4EHD-143-23P-S	1	E5	Spring E	4410E-80-4	1
D6	Set Screws	SC1105A-SS	2	E6	Set Screws	SC1105A-SS	2
D7	Back plate D	(D) 4410D-11-316 (DG) 4410G-11-316	1	E7	Stuffing Box	4410E-83B-316	1
D8	Gasket -Thick	4410G-80-12AG	1	E8	Back plate E	4410E-11-316	1
D9	Seal Seat	4410G-80-11SC	1	E9	Follower	4410E-17-316	1
D10	Gasket -Thin	4410G-80-12G	1	E10	Lock washer	LWA-1300-SS	4
D11	Gland Ring	4410G-17-316L	1	E11	Machine Screw	SC1308E-SS	4
D12	Mounting Bolt	SC1310H-SS	4	E12	O-Ring	17-108-U-25	1
D13	Lock Washer	LWA-1300-SS	4	E13	O-Ring	17-153-U	1

# Exploded View

# Ampco Pumps Company

Figure 6: AC+4329

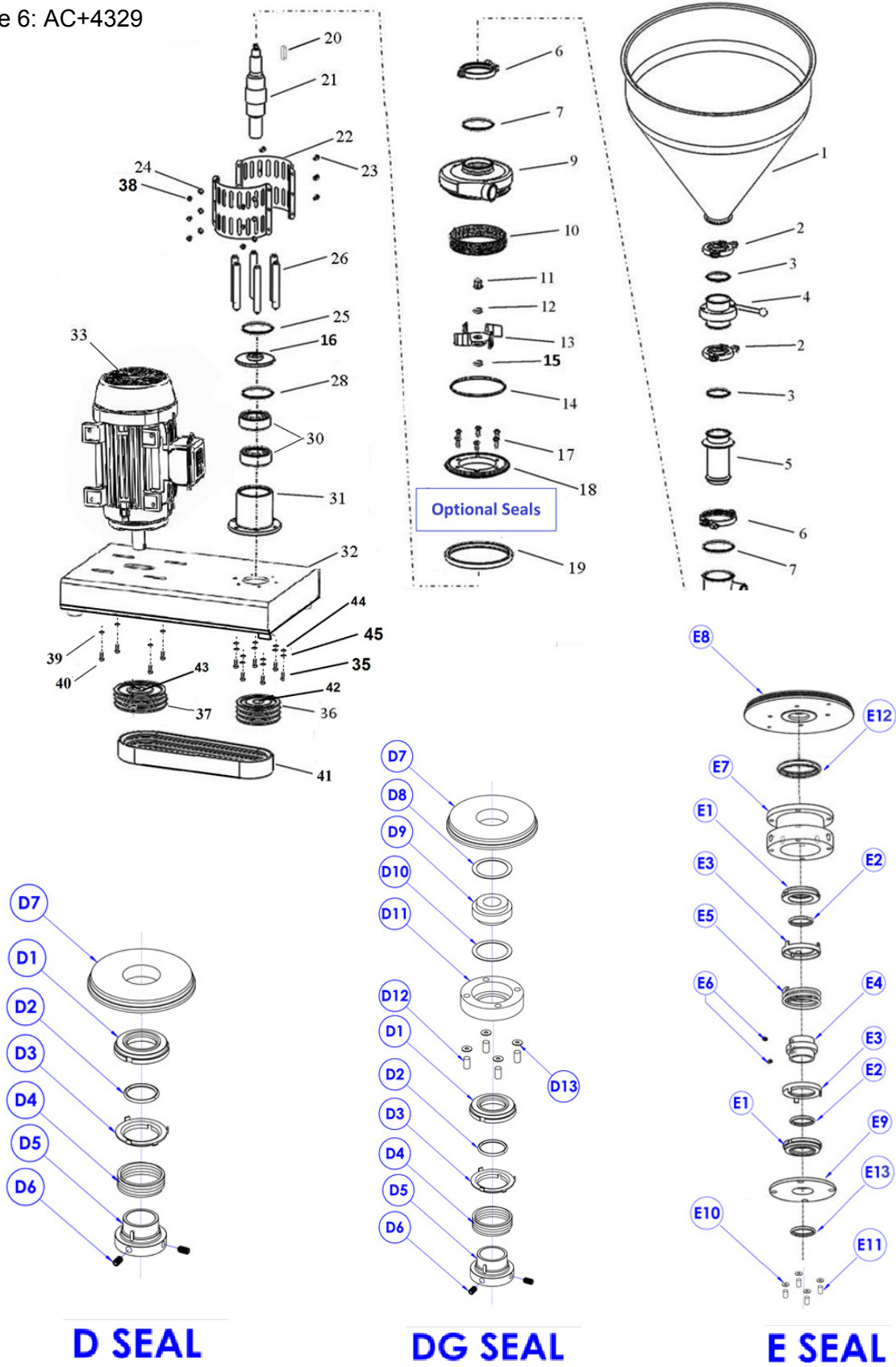

## Troubleshooting

The AC+ Dry Blender requires little maintenance however, it is necessary to sanitize and inspect the equipment regularly. It is expected that occasional problems will occur. This section of the service manual is intended to assist you in determining the cause of the problem, and how to correct the problem you may be having with your blender.

Problems with the motor drive should be directed to the motor manufacturer.

Symptom	Cause	Solution
<b>No suction</b>	Wrong supply pump or need of discharge pump	Verify that pumps are sized correctly to suit application. Contact Ampco Pumps Company if you require assistance
	Leak on the suction side of the supply pump or blender	Tighten all clamps and fittings. Replace worn out gaskets
	Carbon seal is worn	Replace carbon seal on blender and/or supply pump
	Wrong direction of rotation	Reverse a three phase motor by switching any two of the three power leads at the motor or controller
	Liquid inlet port on the wrong side	Remove inlet adapter housing and relocate so it is correctly positioned as shown on the exploded view pages
	Splashing in the suction throat of the Tri-Blender	High Flow– oversized supply pump; Verify that pumps are sized correctly to suit application, and reverse a three phase motor by switching any two of the three power leads at the motor or controller
	High percentage of solids	Install discharge pump on the discharge end of the Tri-Blender
	High temperature	Reduce temperature below 140°F (60°C)
<b>Insufficient discharge</b>	High percentage of solids with screen in casing	Remove Screen
	No liquids	Check supply pump
	Product too viscous or discharge head too great	Add discharge pump
<b>Excessive power consumption</b>	High percentage of solids with screen in casing	Remove Screen
	No liquids	Install discharge pump on the discharge end of the Tri-Blender

Symptom	Cause	Solution
<b>Tri-Blender is noisy</b>	Magnetic hum in motor	Consult motor manufacturer
	Motor bearings are worn	Consult motor manufacturer
	Tri-Blender bearings are worn	Replace bearings
	Foreign matter is rotating with impeller	Remove casing and foreign matter inside, Inspect for damage
<b>Excessive vibration</b>	Blender is not leveled properly	Level blender
	Impeller is damaged	Replace impeller
	Foreign matter in casing	Remove casing and foreign matter, inspect for damage
<b>Dry-Blender leaks</b>	O-ring seal is worn	Replace o-ring seal
	Carbon seal is worn	Replace carbon seal
	Insufficient compression on seal	Replace spring
	Back plate gasket is worn	Replace gasket
	Back plate is worn	Replace back plate
	Clamp is loose	Tighten clamp

## AMPCO PUMPS

Made of SELECTED corrosion-resistant alloys

### TERMS AND CONDITIONS OF SALE

**1. ENTIRE AGREEMENT.** This document contains all of the terms and conditions of the agreement (“the agreement”) between Ampco Pumps Company, Inc. (“Seller”) and the purchaser (“Purchaser”) of the Products (“Products”) to be sold to Purchaser, to the exclusion of any other statements and agreements, and to the exclusion of any terms and conditions incorporated in Purchaser’s order or other documents of Purchaser. Seller’s acceptance of Purchaser’s order is expressly conditioned on Purchaser’s acceptance of the terms and conditions contained herein, and Purchaser, upon placing an order, is presumed to have accepted all the terms and conditions without modification. No alteration, waiver, modification of or addition to the terms and conditions herein shall be binding on Seller unless set forth in writing and specifically agreed to by an officer of Seller. No course of dealing, usage of trade or course of performance will be relevant to supplement or explain any terms used in the agreement. All offers to purchase, quotations and contracts of sale are subject to final acceptance by Seller at its home office at Milwaukee, Wisconsin.

**2. PRICES.** Prices for Products manufactured by Seller pursuant to written accepted orders will remain firm for thirty (30) days from the date of any subsequent price change.

**3. TERMS OF PAYMENT.** Standard terms are ½% 10 days, 30 days net, from date of invoice unless otherwise stated. If, in the judgment of Seller, the financial condition of Purchaser at any time does not justify continuance of production or shipment on the terms of payment specified, Seller may require full or partial payment in advance. In cases of delays in payment, Seller reserves the right to charge interest on delinquent balances at the rate of 1 ½% per month.

**4. DELIVERY.** Except as otherwise provided expressly stated in the agreement, Products are sold F.O.B. Milwaukee. Seller will use reasonable commercial efforts to fill orders within the time stated, but the stated delivery date is approximate only, and Seller reserves the right to readjust shipment schedules without liability. Acceptance by Purchaser of the Products waives any claim for loss or damage resulting from a delay, regardless of the cause of the delay. Except as otherwise provided herein, Seller will not be responsible for freight, transportation, insurance, shipping, storage, handling, demurrage or similar charges. Claims by Purchaser for shortages in the Products must be made to Seller in writing within ten (10) days after date of receipt of the Products. No such shortage shall entitle Purchaser to withhold payment for Products which were received by Purchaser. Each such claim shall set forth in detail the basis and amount of such claim.

**5. TAXES AND FEES.** Seller shall pay all present and future sales, excise, privilege, use or other taxes, customs duties, and all other fees or other costs, imposed by any federal, state, foreign, or local authorities arising from the sale, purchase, transportation, delivery, storage, use or consumption of the Products or will, if applicable, provide Seller with an appropriate exemption certificate. Seller shall be under no obligation to contest the validity of any such taxes or to prosecute any claims for refunds or returns.

**6. INSTALLATION.** The Products shall be installed by and at the expense of Purchaser.

**7. LOSS, DAMAGE OR DELAY.** Seller will not be liable for loss, damage or delay resulting from causes beyond its reasonable control, including, without limitation, strikes or labor difficulties, lockouts, acts or omissions of any governmental authority or Seller, insurrection or riot, war, fires, floods, Acts of God, breakdown of essential machinery, accidents, embargoes, cargo or material shortages, delays in transportation, lack of production capacity or inability to obtain labor, materials or parts from usual sources. In the event of any such delay, performance will be postponed by such length of time as may be reasonably necessary to compensate for the delay. In the event performance by Seller under the agreement cannot be accomplished by Seller due to any of the foregoing causes within a reasonable period of time, Seller may, at its option, terminate the agreement without liability.

**8. RETURNS.** No Products or parts may be returned by Purchaser without the prior written consent of Seller.

**9. WARRANTY.** Seller warrants that the Products manufactured by Seller will be free from defects, material and workmanship under normal use and service for a period of one (1) year from date of shipment. In addition, the specified rating of each pump is warranted; however, the characteristic shape of the performance curves may vary from the published standards, and the capacity, head and efficiency guarantees are based on actual shop tests using clear cold water, and therefore the rating is specified in equivalent units of clear cold water. The sole obligation of Seller and the exclusive remedy of Purchaser for breach of this warranty shall be the repair (at Seller’s facility) or replacement by Seller (F.O.B. Milwaukee, Wisconsin), at Seller’s option, of any parts found to be defective, without charge and shall be conditioned upon Seller receiving written notice of any alleged breach of this warranty within a reasonable time after discovery of the defects, but in no event later than the end of the warranty period. The parts alleged to be defective shall be returned to Seller upon its request, freight prepaid. This warranty does not cover ordinary wear and tear, abuse, misuse, overloading, alteration or Products or parts which have not been installed, operated or maintained in accordance with Seller’s written instructions. Seller shall not be liable for any expenses for repairs, additions or modifications to the Products outside of Seller’s factory without its prior written consent, and any such repairs without such consent shall void this warranty. THIS WARRANTY IS EXCLUSIVE AND IS IN LIEU OF ALL OTHER EXPRESS AND IMPLIED WARRANTIES WHATSOEVER, INCLUDING BUT NOT LIMITED TO IMPLIED WARRANTIES OF MERCHANTABILITY AND FITNESS FOR A PARTICULAR PURPOSE. Seller may from time to time provide its facilities, personnel and experience to assist customers in the selection of materials, design, installation and operation of Products for maximum resistance to corrosion and abrasion with due consideration to the economy of the installation. This service is provided in an advisory capacity only and the final selection and operation of the Products and ancillary equipment shall be the sole responsibility of Purchaser or any user thereof. Accessories and parts manufactured by third parties are warranted only to the extent of such third party’s warranty. IN NO EVENT SHALL SELLER BE LIABLE UNDER ANY CIRCUMSTANCES FOR ANY INCIDENTAL, CONSEQUENTIAL OR SPECIAL DAMAGES (INCLUDING, WITHOUT LIMITATION, ANY LOST PROFITS OR LABOR COSTS) ARISING FROM THE BREACH OF THIS WARRANTY OR OTHERWISE ARISING FROM OR RELATING TO THE PRODUCTS OR THEIR SALE, USE OR INSTALLATION.

# Terms and Conditions

# Ampco Pumps Company

**10. CHANGES.** Changes in any work to be performed hereunder may be made only upon Purchaser's written instructions and acceptance by Seller in its discretion. Any change in drawings, materials or design of the Products, or to tools, fixtures or other items used to produce the Products, which affects Seller's cost to produce the Products will entitle Seller to adjust the price to take into account any additional costs. If work has been started, Seller shall be properly reimbursed for work already performed; if Products already produced are not accepted by Purchaser, Seller has the right to adjust the price to take into account any additional costs caused by an increase or decrease in quantities or in the time required for performance under the agreement.

**11. TERMINATION.** After Seller has commenced work, ordered any materials or made any other commitments pursuant to the agreement, it may be terminated only with the prior written agreement of Seller providing for equitable cancellation charges. Such charges shall reimburse Seller for any completed items at the contract price, and for any work-in-process items at the contract price less the cost to complete. Termination on any other basis must be specifically agreed on in writing in advance between Purchaser and Seller.

**12. DEFERRED DELIVERIES.** Orders or deliveries will be deferred only upon the prior written agreement of Seller in its discretion, and then only upon the following conditions:

(a) The deferral period may not exceed sixty (60) days. At the end of the deferral period, if no release is provided by Purchaser, Seller reserves the right to render an invoice for and ship the completed portion of the order to the destination specified in Purchaser's order, or to store such material at Purchaser's expense at Seller's standard storage charges then in effect.

(b) For the portion of the order that is not completed, if no release is provided by Purchaser at the expiration of the deferral period, Seller reserves the right to render an invoice for any completed items at the contract price, and for any work-in-process items at the contract price less the cost to complete.

(c) Purchaser shall bear the risk of loss or damage to materials held at Purchaser's request.

**13. LIMITATION OF LIABILITY.** IN NO EVENT SHALL SELLER BE LIABLE UNDER ANY CIRCUMSTANCES: (a) FOR ANY INCIDENTAL, CONSEQUENTIAL OR SPECIAL DAMAGES (INCLUDING, WITHOUT LIMITATION, ANY LOST PROFITS OR LABOR COSTS) ARISING FROM OR RELATING TO THE PRODUCTS OR THEIR SALE, USE OR INSTALLATION; (b) FOR DAMAGES TO PROPERTY (OTHER THAN THE PRODUCTS PURCHASED FROM SELLER); (c) FROM ANY BREACH OF ITS WARRANTY OR ANY OTHER OBLIGATIONS TO BUYER; OR (d) FOR ANY OTHER CAUSE WHATSOEVER, WHETHER BASED ON WARRANTY (EXPRESSED OR IMPLIED) OR OTHERWISE BASED ON CONTRACT, OR ON TORT OR OTHER THEORY OF LIABILITY, AND REGARDLESS OF ANY ADVICE OR REPRESENTATIONS (WHETHER OR NOT IN WRITING) THAT MAY HAVE BEEN RENDERED BY SELLER CONCERNING THE DESIGN, MANUFACTURE, SALE, USE OR INSTALLATION OF THE PRODUCTS.

**14. INFRINGEMENT.** Seller at its expense will defend and hold Purchaser harmless from and against all damages, costs and expenses arising from any valid claim of infringement by a third party with respect to any patent or other intellectual property rights (collectively, the "Intellectual Property Rights") caused by Products originally manufactured by Seller, provided Purchaser (a) has not modified such Products, (b) gives Seller immediate notice in writing of any claim or commencement or threat of suit, and (c) permits Seller to defend or settle the same, and gives all immediate information, assistance and authority to enable Seller to do so. In the event any such originally manufactured Products are held to infringe an Intellectual Property Right and if Purchaser's use thereof is enjoined, Seller will, at its expense and option: (1) obtain for Purchaser the right to continue using the Products, (2) supply non-infringing Products, (3) modify the Products so that they become non-infringing, or (4) refund the then market value of such Products. In no event shall Seller's liability exceed the sale price of the infringing Products. THE FOREGOING REPRESENTS SELLER'S ENTIRE AND EXCLUSIVE OBLIGATION WITH RESPECT TO ANY CHARGE OF INFRINGEMENT OF ANY INTELLECTUAL PROPERTY RIGHT AND IS IN LIEU OF ANY STATUTORY WARRANTY RELATING TO INFRINGEMENT. Notwithstanding the foregoing, Seller shall have no liability as to any Products or parts thereof that are manufactured or modified by Purchaser or a third party, or that are manufactured or modified by Seller in accordance with Purchaser's specifications. Purchaser will defend and hold Seller harmless from and against all damages, costs and expenses whatsoever arising from any claim for infringement of any Intellectual Property Rights relating to Products that have been manufactured or modified by Seller according to specifications provided by Purchaser.

**15. CERTAIN LAWS.** Seller will comply with the applicable requirements of the Fair Labor Standards Act of 1938, as amended, Executive Order 11246, and THE rules, regulations and orders of the Secretary of Labor relating thereto.

**16. PERIOD FOR ACCEPTING QUOTATIONS.** Unless accepted without modification within thirty (30) days of issuance, or prior to withdrawal by Seller if earlier, all quotations automatically expire at the end of such thirty (30) day period.



# Terms and Conditions

# Ampco Pumps Company

**17. PROVISIONS FOR INTERNATIONAL TRANSACTIONS.** The following provisions shall apply if the Products are to be shipped to Purchaser at a location outside the United States, and apply regardless of other provisions set forth in these Terms and Conditions:

(a) The 1980 United Nations Convention on Contracts for the International Sale of Products shall not apply.

(b) Except as otherwise provided expressly stated in the agreement, terms of delivery are Ex-Works (within the meaning of INCOTERMS 2000) and all customs fees, import duties, cargo insurance, taxes and other charges imposed on or relating to the purchase or sale of the Products shall be paid by Purchaser in addition to the stated price.

(c) Except as otherwise provided expressly stated elsewhere in the agreement, payment shall be made by issuance to Seller of an irrevocable letter of credit which (i) is issued and confirmed by a U.S. bank acceptable to Seller, (ii) is governed by the Uniform Customs and Practice for Documentary Credits (UCP 600) and otherwise acceptable in form and substance to Seller, and (iii) provides for payment to Seller of the purchase price in U.S. dollars upon presentation by Seller of Seller's certification and/or such other documents as shall be required by the letter of credit. All banking and other charges for such letter of credit shall be for the account of Purchaser.

(d) Prices include Seller's standard commercial export packaging which may vary depending on whether shipment is made by air, land or sea. Except as otherwise provided expressly stated in the agreement, Purchaser will bear any additional expenses required to satisfy Purchaser's packaging requirements. Packages will be marked in accordance with Purchaser's instructions, if any. Seller shall furnish packing lists and such other information as may be necessary to enable Purchaser's agent to prepare documents required for export shipment.

(e) All shipments hereunder are subject to compliance with the U.S. Export Administration Act, as amended, regulations thereunder and all other U.S. laws and regulations concerning exports. Purchaser shall comply with all such laws and regulations concerning the use, disposition, re-export and sale of the Products provided hereunder.

**18. GENERAL.** No modification or waiver of the agreement or any of its provisions is valid unless expressly agreed to by Seller in writing, and no waiver by Seller of any default under the agreement is a waiver of any other or subsequent default. The unenforceability or invalidity of one or more of the provisions of the agreement will not affect the enforceability or validity of any other provision of the agreement. Purchaser may not assign any of its rights, duties or obligations under the agreement without Seller's prior written consent and any attempted assignment without such consent, even if by operation of law, will be void. The agreement is governed by and shall be construed in accordance with the laws of the State of Wisconsin, including the Uniform Commercial Code as enacted by such state, without giving effect to its conflict of laws principles.

## **Return Policy**

## **Ampco Pumps Company**

This policy is intended for returns that are not covered by product warranty, i.e. wrong pump or part was ordered, customer canceled order, etc. Before returning any product, contact us for a Returned Material Authorization Number (RMA#). This will eliminate confusion when the parts are received and facilitate processing the return. No action will be taken on returned parts without an RMA.

<u>Type of Return</u>	<u>Restocking Charge</u>
Standard pump with a replacement order	10%
Standard pump without a replacement order	20%
Standard parts with a replacement order	5%
Standard parts without a replacement order	10%

Additional restocking charges may be assessed for any of the following circumstances.

1. Special order motors and seals are not returnable unless we have a use for them. Credit will be determined on a case-by-case basis.
2. Impellers that are trimmed to a diameter that we don't regularly use are not returnable. Credit will be determined on a case-by-case basis.
3. Used seals and motors are not returnable.
4. For any pumps and/or parts purchased over (1) year ago, credit will be determined on a case-by-case basis.

### Credits

Credit will be issued only after parts are returned and inspected. Customer is responsible for packaging parts so they are returned in "as new" condition. Any labor required by Ampco to return the parts to "as new" condition will be deducted from the credit.

**Notes**



**Ampco Pumps Company**  
**2045 W. Mill Road**  
**Glendale, WI 53209**  
**Phone: (800) 737-8671 or (414) 643-1852**  
**Fax: (414) 643-4452**  
**Email: [ampcocs@ampcopumps.com](mailto:ampcocs@ampcopumps.com)**

For additional information on the ROLEC DH series and other Ampco Pumps products, please visit our website: [www.ampcopumps.com](http://www.ampcopumps.com)