

# Ampco Pumps Company



## IC+ Pumps

- Centrifugal Pumps
  - Installation and Maintenance Manual



# Table of Contents

# Ampco Pumps Company

---

<b>Introduction .....</b>	<b>3</b>
Introduction .....	3
General Information .....	3
Shipping Damage or Loss .....	3
<b>Receiving/Safety .....</b>	<b>4</b>
Pump Receiving .....	4
Safety .....	4
<b>Pump Information .....</b>	<b>5</b>
Instructions .....	5
Location .....	5
Installation .....	5
Starting .....	6
<b>Maintenance .....</b>	<b>6</b>
<b>Service .....</b>	<b>7</b>
<b>Single Mechanical Seal .....</b>	<b>10</b>
<b>Pump Specs .....</b>	<b>11</b>
<b>Troubleshooting .....</b>	<b>12</b>
<b>Ampco Pumps Terms and Conditions .....</b>	<b>13</b>
<b>Return Policy .....</b>	<b>16</b>

### **Introduction**

To ensure the best results and service, please read and fully understand this manual prior to putting this pump into service. For any questions regarding operation, maintenance, or installation, please contact your local distributor or Ampco Pumps Company:

*Ampco Pumps Company  
2045 W. Mill Road  
Glendale, WI 53209  
Phone: (800) 737-8671 or (414) 643-1852  
Fax: (414) 643-4452  
Email: [ampcocs@ampcopumps.com](mailto:ampcocs@ampcopumps.com)*

### **General Information**

Each Ampco “IC+” Series pump is fully assembled, lubricated, and tested at the factory and shipped ready for use. Standard maintenance practices are outlined in this manual. For more information, please refer to Maintenance. Following these guidelines will provide long-lasting, trouble-free service when the pump is incorporated into a properly designed system.

### **Shipping Damage or Loss**

Upon receiving equipment that is damaged or if your shipment is lost in transit, immediately file a claim with the carrier. At time of pick-up, the carrier signed the bill of lading, acknowledging that they have received the product from Ampco in good condition.

---

**Pump Receiving**

Ampco covers the pump inlet and discharge ports prior to shipping, ensuring that foreign matter does not enter the pump during shipment. If the protective covers are missing upon arrival, remove the pump cover and inspect to ensure it is free from contaminate before turning the shafts. Please make note of the pump serial number; this will assist in the process of ordering replacement parts and/or a warranty claim. For more information regarding shipment damage or warranty, please refer to Terms and Conditions.

**Safety**

**IMPORTANT:** Read and understand this manual **BEFORE** installation, operation, or maintenance of the pump. Improper installation, operation, or maintenance may result in severe injury or death. Equipment damage caused by user neglect will invalidate the pump warranty.

There are safety symbols used throughout this manual identifying safety concerns.



***WARNING:*** Hazards or unsafe practices that COULD result in severe personal injury or death, and how to avoid them.

***CAUTION:*** Hazards or unsafe practices that COULD result in minor personal injury or damage to product or property.

### **Instructions**

Your Ampco centrifugal pump is designed to provide years of low cost pumping service. There is a small amount of necessary care required to ensure you of this expected long service. It is recommended that you carefully review the installation and operating sections in this manual.

Every Ampco pump receives a careful running test at the factory to ensure mechanical soundness. Special instructions and advice for unusual conditions, such as corrosive, abrasive, and other problems are too numerous to be included in this manual, but will be the subject of specific discussion on orders or inquires for special applications.

### **Location**

The immediate environment in which the unit is located, while usually of prime importance to the pump, may determine the enclosure needed for the motor. Ampco can supply several different motor enclosures to meet specific requirements. The IC+ Series pumps are supplied with totally enclosed motors as standard. They may be installed where dirt, moisture, and mild corrosion are present or in outdoor locations. Wash-down duty motors, with epoxy paint or paint free stainless steel, are designed for applications where the motor is frequently subject to wash-down to maintain a bacteria-free operating environment. Specialty motors may be required for moist, corrosive, or explosive environments. Motor drain plugs (if not equipped with automatic drains) must be removed periodically to drain accumulated condensation.

Pump units should be located where daily visual inspection is possible and no surrounding structure interferes with ventilating air over or through the motor. Submerged suction is the most economical and convenient method of priming a pump when installed in such a position that the top of the casing is below the surface of the liquid to be pumped. The liquid will flow by gravity into the pump and displace the air (through the discharge if possible or a vent when available).

### **Installation**

Begin with a suction line as direct and as simple as possible. The suction line is usually the most sensitive part of the pumping system, being totally dependent on outside forces to provide liquid flow into the center of the impeller.

Locate the pump as close to the supply of liquid as possible, with short and direct suction piping. Use wide radius elbows to help reduce friction loss. Air pockets due to high sections, concentric reducers, valve bonnets, etc. should be eliminated by installing a suction having a continual rise or a straight horizontal run with an air eliminator near the pump suction entry. To prevent air pockets use eccentric pipe reducers that are mounted in a horizontal position across the top of the pipeline. Position valves such that they are in a position other than upright as an air pocket may exist in the upright valve bonnet.

Above all, remember that until the liquid reaches the leading edges of the rotating impeller vane the pump cannot impart its energy to move the liquid. If possible, try not to connect an elbow directly to the inlet of the pump. This may cause excessive turbulence and hinder pump performance.

## Starting

The pump must be primed before starting, as the mechanical seal depends on the liquid being pumped for lubrication and cooling. Even a short run to determine direction of rotation without first priming may seriously damage the seal. The correct direction of rotation is counter-clockwise when viewed from the suction end of the pump. It is recommended to turn the pump by hand before starting the first time to ensure the unit is not binding.

## Maintenance

Since long-term breakdown cannot be tolerated in most services, maintenance procedures and a contingency plan must be established in advance to minimize any production loss caused by down time. During building and start-up it is common to use outside personnel. Operating personnel should acquaint themselves with the pump, particularly its running performance. This will aid in establishing a standard for future reference. This manual and other information provided with the pump should be filed for future reference.

All possible performance data should be recorded once the system is functioning properly and stable. Suction and discharge pressure readings, flow rate, seal leakage rate, bearing temperature, noise, and vibration levels provide input to a pump's performance in the system. It is unlikely that all of this data can be measured, but any information gathered can help alert the user of problems with the pump or system.

Operating personnel should know that any changes in the system or the liquid being pumped might have an effect on the pump's performance. It is advisable to also record the fluid temperature, specific gravity, viscosity, liquid concentration, percent of solid concentration, other additives, and properties. A proper maintenance procedure should begin with a file for each pump. All known data relative to the pump, fluid handled, and system should be included. A complete record of maintenance and repair costs along with a log of the unit's operating hours should be kept.

In addition, complete pump identification— size, type, operating speed, manufacturer, serial number, model number, and material of construction should be noted.

### Maintenance Procedures

Daily Check—possibly the most important inspection will be the daily observation.

1. Seal leakage rate
2. Pressure reading and flow indication
3. Change in operating sound
4. Change in bearing temperature

Semi-Annual Inspection—typically made at 6 month intervals with results noted in pump's maintenance file.

1. Check of mechanical seal assembly
2. Check of bearing lubrication

Annual Inspection—includes Semi-Annual inspection plus:

3. Removal of seal for inspection
4. Bearing check
5. Check of axis/running clearance of impeller

### Contingency Plan

For inspection findings and breakdowns, a contingency plan should be developed. To begin with, an adequate supply of probable replacement parts should be kept on hand.

The minimum recommended spare parts are as follows:

1. Mechanical Seal Kit
2. Casing Gasket
3. Impeller Key

In addition, Ampco recommends

4. Stub Shaft
5. Impeller
6. Impeller Nut

Where service cannot be interrupted, a complete stand-by pump is recommended.

### Disassemble and Replace Parts as Follows:

Before attempting any service on the pump or motor, disconnect or lock out electrical power to the pump motor. If the pump and motor are to be removed as a unit, note the wiring configuration. Use colored or numbered tape to mark the wire connections of the motor and power source for reconnection.

These instructions are limited to fluid ends only. See other drawings and literature applicable to motors, pedestals, frames, shafts, bearings, etc. if additional repairs are required.

1. Remove the casing by removing the casing clamp. There is a choice of (a) first removing the inlet and discharge piping, or (b) sliding the motor and remaining pump parts back and free of the casing without disturbing the piping. A rubber mallet may be necessary to remove the casing.

2. Remove the impeller nut using a 5/8" socket (114 model) or 7/8" socket (216, 218, 328, 4410 models) and holding the stub shaft with a 3/8" rod in the predrilled hole. Ease the impeller off the shaft. Pinch bars between the impeller and cover may be required. Be careful not to mar the pump's surface finish. Remove the impeller key.

3. Remove the rotating parts of the mechanical seal by simply pulling them off the shaft. If the rotating seal does not come off the shaft, you may leave it on and it will come off with the backplate. Be very careful not to drop it on the floor when you pull the backplate off.

4. Gently slide the backplate off the pump shaft. 216, 218, 328, and 4410 models require the backplate to be rotated to release the backplate pins.

5. Press the seal's stationary seat with the cup o-ring out of the backplate.

6. Thoroughly clean the seal cavity and shaft, and dry with a clean cloth.

**The mechanical seal is the only expendable pump part. It is suggested that the complete mechanical seal, both stationary and rotating members, be replaced whenever dripping or leakage occurs at the shaft, or whenever parts are removed to the point of separating the primary sealing surfaces.**

The fluid end is now completely disassembled: Additional procedures are dictated by purpose for which the unit was disassembled.

### **Mechanical Seal Replacement and Reassembly**

Please see the table on page 10 for proper identification of all pump components.

Oiling (use food grade lubricants if required) the O.D. of the stub shaft and I.D. of the seal facilitates this by softening an adhesive film on the seal (use soap, glycerin, etc. if oil is not permitted i.e. EPDM). Do not use grease, as this would prevent the adhesive film from resetting. Final adherence to the sleeve is essential for shaft, sleeve, and seal to rotate as a unit.

1. Lightly oil bore and finger press stationary seat with gasket or o-ring into this cavity. The seat is fragile. Do not abuse.

2. Slip the backplate and seat over the shaft into its locating bore. 216, 218, 328, and 4410 models require the backplate to be rotated to engage the backplate pins. Avoid bumping the seat into the shaft.

3. Oil and hand fit (no tools) the rotating portion of the mechanical seal onto the stub shaft. Check direction of seal face, seal face should face the stationary seat. Push the rotating seal against the stationary seal (use the spring if necessary, remove the spring after the seal is set to ease the installation of other parts).

4. Place the gasket in the end of the stub shaft (a little grease will help hold the gasket in place). Insert the key onto the shaft. Install the spring onto the rotating seal, being careful not to bump the gasket. Slide the impeller onto the shaft over the key. Hand tighten the impeller nut with the gasket installed on the impeller nut.

5. Tighten the impeller nut with a 6 point socket to the recommended torque (page 11). Check the freedom of parts by rotating the impeller by hand.

6. Install a new casing gasket on the shoulder of the backplate. Place the casing in position and secure with the casing clamp. Tighten the clamp. Rotate the impeller by hand again to check for rubbing.

**One way to damage a new seal is to run it dry. Be sure the pump is in place and primed before operating.**

7. Place the pump back into service and inspect for proper rotation and leaks.

### **Motor/Pump Shaft Disassembly**

Before attempting any service on the pump or motor, disconnect or lock out electrical power to the pump motor. If the pump and motor are to be removed as a unit, note the wiring configuration. Use colored or numbered tape to mark the wire connections of the motor and power source for reconnection.

1. Begin with pump disassembly as noted previously.



2. Loosen the shaft collar with an Allen wrench so that the stub shaft can be taken off the motor. A rubber mallet may be used to tap the stub shaft if it will not slide off. Be careful not to drop the shaft collar when the stub shaft comes off the motor.

2a. If the stub shaft does not come off, the backplate, impeller, impeller nut gasket, and impeller nut may be assembled onto the shaft to help pull the stub shaft off (make sure that all seal pieces are out of the backplate). A cloth between the backplate and impeller is necessary in this step. Pull on the backplate or gently tap it with a rubber mallet to create enough force to free the stub shaft from the motor.

At this time the motor can be replaced by unbolting the adapter from it and separating the two items.

### Motor/Pump Shaft Disassembly

If the pump stub shaft is being replaced, it is recommended that a new shaft collar also be installed.

1. Begin by bolting the adapter onto the motor. Please note correct tightness of all fastening components in the table on page 11.

2. Slide the shaft collar onto the stub shaft and slide the two together onto the motor shaft, keeping the motor keyway in line with one of the slots in the stub shaft. If the collar has an identification groove in it, this will rest against the step in the stub shaft.

3. Line up the slot in the collar with the stub shaft slot and motor keyway gap. Do not tighten the shaft collar yet. Since the shaft was disassembled, the impeller clearance in the pump may have changed. The impeller must be repositioned to ensure the impeller will not rub and also for proper pump performance. The pump will be assembled without the seal kit in order to do this. The critical impeller gap is the gap between the backplate and the nearest impeller blade to it. The blades may not all be at the same distance due to manufacturing and balance procedures. The gap between the impeller and the backplate should be 1/16".

4. Slide the backplate over the pump shaft and shoulder it against the adapter. On 216, 218, 328, and 4410 models rotate the cover to engage the backplate pins.

5. Install the impeller key, and impeller (gaskets do not need to be installed at this time). Tighten the impeller nut to secure the assembly.

6. With a rubber mallet, gently tap the impeller nut to drive the stub shaft towards the motor while checking the gap between the impeller and backplate. This will create the critical impeller gap.

7. When the impeller gap is correct, align the shaft collar slot with the slot in the stub shaft and the motor shaft keyway, and tighten the shaft collar with a torque wrench to secure the shaft position.

8. Remove the impeller nut, gasket, and impeller from the shaft. Now remove the backplate and begin with the seal and pump assembly instructions.

# Single Internal Mechanical Seal

# Ampco Pumps Company

Detail #	Quantity	Part Name	Detail #	Quantity	Part Name
132	1	Shaft Guard Cap Screw	25A	1	Impeller Nut Gasket
131	1	Shaft Guard	25	1	Impeller Nut
90	1	Casing Gasket	19	1	Motor
80	1	Single Mechanical Seal	16 <sup>1</sup>	2	Drive Screw
75	1	Casing Clamp	15 <sup>1</sup>	1	Name Plate
71B	4	Cap Screw (Motor/Adapter)	11	1	IC+ Backplate
71	1	Adapter	6P	1	Stub Shaft
27	1	Impeller Key	2P	1	Impeller
26	1	Shaft Collar	1	1	Casing
25B	1	Impeller Back Gasket	<sup>1</sup> Not Shown		

Note: Please be sure to always include pump type, size, and serial number with any reference to above numbers and names.

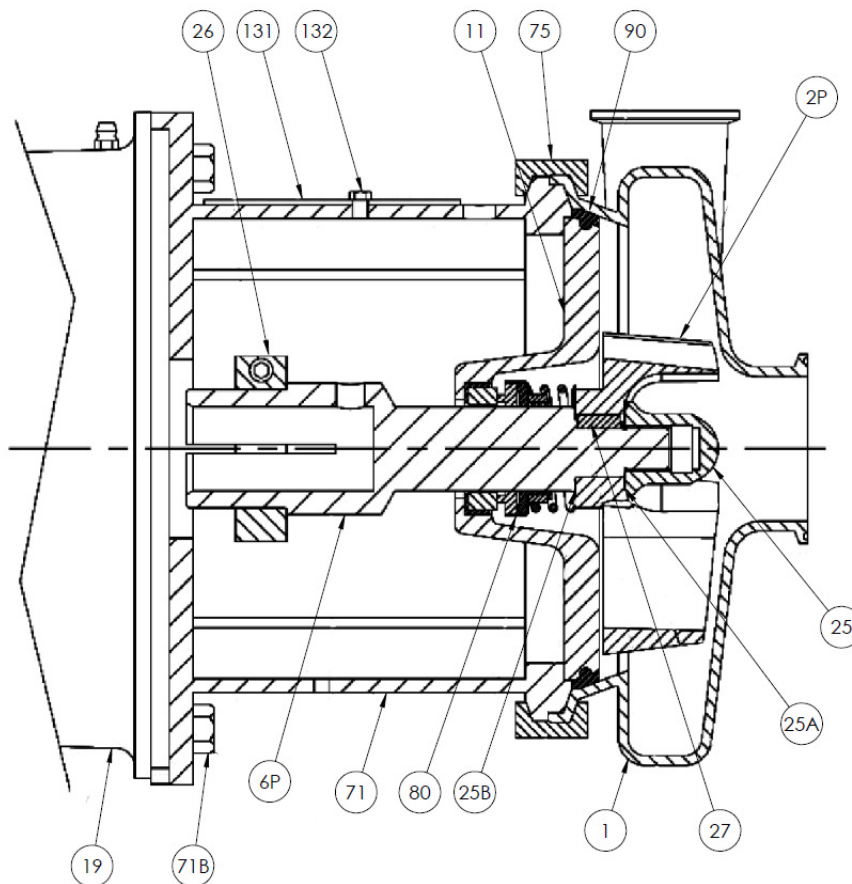

## Proper Torque for Bolts on IC+ Series Pumps

<b>Item</b>	<b>Torque ft-lbs</b>	<b>Pump Included</b>
Motor Bolts	20	140 Frame
	55	180-250 Frame
	70	280 Frame
	110	320 Frame
Shaft Collar Bolt(s)	6	180 Frame
	15	210-250 Frame
	40	280-320 Frame
Impeller Nut	15	114 pump
	80	218/216/328/4410

## Required Tools

1. Rubber Mallet
2. 5/8" socket - for impeller nut 114 pump  
7/8" socket - for impeller nut 216/218/328/4410 pumps
3. 3/8" diameter steel rod - to hold stub shaft
4. Appropriate lubricant
5. 3/16" Allen wrench - shaft collar bolt 140-180 frames  
1/4" Allen wrench - shaft collar bolt 210-280 frames  
5/16" Allen wrench - shaft collar bolts 320 frame
6. Impeller puller/pinch bars (may be necessary)
7. 1/16" Gauge for checking impeller gap

It is to the user's advantage to be familiar with a systematic procedure to determine reasons and causes for unsatisfactory pump operation. The following list of troubles and causes is intended to assist users in determining the cause of any pumping trouble. Faulty installations can then be corrected and a clear description given to the manufacturer if assistance is required. Human judgement should not be relied on to measure operating conditions. Use proper instruments to measure values of pressure, suction lift, speeds, temperature rise of motors, etc. When motor speeds are incorrect, check connections and measure voltage at the motor terminals.

1. No liquid delivered
  - a. Pump and suction line not completely primed
  - b. Speed too low
  - c. Required discharge too high
  - d. Suction lift too high
  - e. Impeller, piping, or fittings completely plugged up
  - f. Wrong direction of rotation
2. Not sufficient capacity
  - a. Air leaks in suction pipe or shaft seal
  - b. Speed too low
  - c. Required discharge head too high
  - d. Suction lift too high or insufficient NPSH available
  - e. Impeller, piping, or fittings partially plugged
  - f. Insufficient positive suction head for hot water or other volatile liquids
  - g. Liquid viscosity too high
  - h. Mechanical problems- wear rings worn, impeller damaged, shaft seal defective
  - i. Wrong direction of rotation
  - j. Suction pipe entrance too close to surface of liquid
  - k. Air pocket in pipe high points
3. Not sufficient pressure
  - a. Speed too low
  - b. Mechanical problems- wear rings worn, impeller damaged, shaft seal defective
  - c. Small impeller diameter
  - d. Air or gas in liquid
  - e. Wrong direction of rotation
  - f. Air pockets in pipe high points
4. Pump operates for a while, then quits
  - a. Leaky suction line
  - b. Air leaking in through shaft seal
  - c. Suction lift too high or insufficient NPSH available
  - d. Air or gas in liquid
  - e. Suction piping and fitting not completely freed of air during priming
  - f. Air pockets in pipe high points
5. Pump takes too much power
  - a. Speed too high
  - b. Pumping too much water because required head is lower than anticipated
  - c. Viscosity and/or specific gravity is higher than specified
  - d. Mechanical problems- binding at wear rings from distortion due to piping strains, shaft bent, impeller rubbing casing, and/or stuffing box too tight
  - e. Wrong direction of rotation

## AMPCO PUMPS

Made of SELECTED corrosion-resistant alloys

### TERMS AND CONDITIONS OF SALE

**1. ENTIRE AGREEMENT.** This document contains all of the terms and conditions of the agreement (“the agreement”) between Ampco Pumps Company, Inc. (“Seller”) and the purchaser (“Purchaser”) of the Products (“Products”) to be sold to Purchaser, to the exclusion of any other statements and agreements, and to the exclusion of any terms and conditions incorporated in Purchaser’s order or other documents of Purchaser. Seller’s acceptance of Purchaser’s order is expressly conditioned on Purchaser’s acceptance of the terms and conditions contained herein, and Purchaser, upon placing an order, is presumed to have accepted all the terms and conditions without modification. No alteration, waiver, modification of or addition to the terms and conditions herein shall be binding on Seller unless set forth in writing and specifically agreed to by an officer of Seller. No course of dealing, usage of trade or course of performance will be relevant to supplement or explain any terms used in the agreement. All offers to purchase, quotations and contracts of sale are subject to final acceptance by Seller at its home office at Milwaukee, Wisconsin.

**2. PRICES.** Prices for Products manufactured by Seller pursuant to written accepted orders will remain firm for thirty (30) days from the date of any subsequent price change.

**3. TERMS OF PAYMENT.** Standard terms are ½% 10 days, 30 days net, from date of invoice unless otherwise stated. If, in the judgment of Seller, the financial condition of Purchaser at any time does not justify continuance of production or shipment on the terms of payment specified, Seller may require full or partial payment in advance. In cases of delays in payment, Seller reserves the right to charge interest on delinquent balances at the rate of 1 ½% per month.

**4. DELIVERY.** Except as otherwise provided expressly stated in the agreement, Products are sold F.O.B. Milwaukee. Seller will use reasonable commercial efforts to fill orders within the time stated, but the stated delivery date is approximate only, and Seller reserves the right to readjust shipment schedules without liability. Acceptance by Purchaser of the Products waives any claim for loss or damage resulting from a delay, regardless of the cause of the delay. Except as otherwise provided herein, Seller will not be responsible for freight, transportation, insurance, shipping, storage, handling, demurrage or similar charges. Claims by Purchaser for shortages in the Products must be made to Seller in writing within ten (10) days after date of receipt of the Products. No such shortage shall entitle Purchaser to withhold payment for Products which were received by Purchaser. Each such claim shall set forth in detail the basis and amount of such claim.

**5. TAXES AND FEES.** Seller shall pay all present and future sales, excise, privilege, use or other taxes, customs duties, and all other fees or other costs, imposed by any federal, state, foreign, or local authorities arising from the sale, purchase, transportation, delivery, storage, use or consumption of the Products or will, if applicable, provide Seller with an appropriate exemption certificate. Seller shall be under no obligation to contest the validity of any such taxes or to prosecute any claims for refunds or returns.

**6. INSTALLATION.** The Products shall be installed by and at the expense of Purchaser.

**7. LOSS, DAMAGE OR DELAY.** Seller will not be liable for loss, damage or delay resulting from causes beyond its reasonable control, including, without limitation, strikes or labor difficulties, lockouts, acts or omissions of any governmental authority or Seller, insurrection or riot, war, fires, floods, Acts of God, breakdown of essential machinery, accidents, embargoes, cargo or material shortages, delays in transportation, lack of production capacity or inability to obtain labor, materials or parts from usual sources. In the event of any such delay, performance will be postponed by such length of time as may be reasonably necessary to compensate for the delay. In the event performance by Seller under the agreement cannot be accomplished by Seller due to any of the foregoing causes within a reasonable period of time, Seller may, at its option, terminate the agreement without liability.

**8. RETURNS.** No Products or parts may be returned by Purchaser without the prior written consent of Seller.

**9. WARRANTY.** Seller warrants that the Products manufactured by Seller will be free from defects, material and workmanship under normal use and service for a period of one (1) year from date of shipment. In addition, the specified rating of each pump is warranted; however, the characteristic shape of the performance curves may vary from the published standards, and the capacity, head and efficiency guarantees are based on actual shop tests using clear cold water, and therefore the rating is specified in equivalent units of clear cold water. The sole obligation of Seller and the exclusive remedy of Purchaser for breach of this warranty shall be the repair (at Seller’s facility) or replacement by Seller (F.O.B. Milwaukee, Wisconsin), at Seller’s option, of any parts found to be defective, without charge and shall be conditioned upon Seller receiving written notice of any alleged breach of this warranty within a reasonable time after discovery of the defects, but in no event later than the end of the warranty period. The parts alleged to be defective shall be returned to Seller upon its request, freight prepaid. This warranty does not cover ordinary wear and tear, abuse, misuse, overloading, alteration or Products or parts which have not been installed, operated or maintained in accordance with Seller’s written instructions. Seller shall not be liable for any expenses for repairs, additions or modifications to the Products outside of Seller’s factory without its prior written consent, and any such repairs without such consent shall void this warranty. THIS WARRANTY IS EXCLUSIVE AND IS IN LIEU OF ALL OTHER EXPRESS AND IMPLIED WARRANTIES WHATSOEVER, INCLUDING BUT NOT LIMITED TO IMPLIED WARRANTIES OF MERCHANTABILITY AND FITNESS FOR A PARTICULAR PURPOSE. Seller may from time to time provide its facilities, personnel and experience to assist customers in the selection of materials, design, installation and operation of Products for maximum resistance to corrosion and abrasion with due consideration to the economy of the installation. This service is provided in an advisory capacity only and the final selection and operation of the Products and ancillary equipment shall be the sole responsibility of Purchaser or any user thereof. Accessories and parts manufactured by third parties are warranted only to the extent of such third party’s warranty. IN NO EVENT SHALL SELLER BE LIABLE UNDER ANY CIRCUMSTANCES FOR ANY INCIDENTAL, CONSEQUENTIAL OR SPECIAL DAMAGES (INCLUDING, WITHOUT LIMITATION, ANY LOST PROFITS OR LABOR COSTS) ARISING FROM THE BREACH OF THIS WARRANTY OR OTHERWISE ARISING FROM OR RELATING TO THE PRODUCTS OR THEIR SALE, USE OR INSTALLATION.

**10. CHANGES.** Changes in any work to be performed hereunder may be made only upon Purchaser's written instructions and acceptance by Seller in its discretion. Any change in drawings, materials or design of the Products, or to tools, fixtures or other items used to produce the Products, which affects Seller's cost to produce the Products will entitle Seller to adjust the price to take into account any additional costs. If work has been started, Seller shall be properly reimbursed for work already performed; if Products already produced are not accepted by Purchaser, Seller has the right to adjust the price to take into account any additional costs caused by an increase or decrease in quantities or in the time required for performance under the agreement.

**11. TERMINATION.** After Seller has commenced work, ordered any materials or made any other commitments pursuant to the agreement, it may be terminated only with the prior written agreement of Seller providing for equitable cancellation charges. Such charges shall reimburse Seller for any completed items at the contract price, and for any work-in-process items at the contract price less the cost to complete. Termination on any other basis must be specifically agreed on in writing in advance between Purchaser and Seller.

**12. DEFERRED DELIVERIES.** Orders or deliveries will be deferred only upon the prior written agreement of Seller in its discretion, and then only upon the following conditions:

(a) The deferral period may not exceed sixty (60) days. At the end of the deferral period, if no release is provided by Purchaser, Seller reserves the right to render an invoice for and ship the completed portion of the order to the destination specified in Purchaser's order, or to store such material at Purchaser's expense at Seller's standard storage charges then in effect.

(b) For the portion of the order that is not completed, if no release is provided by Purchaser at the expiration of the deferral period, Seller reserves the right to render an invoice for any completed items at the contract price, and for any work-in-process items at the contract price less the cost to complete.

(c) Purchaser shall bear the risk of loss or damage to materials held at Purchaser's request.

**13. LIMITATION OF LIABILITY.** IN NO EVENT SHALL SELLER BE LIABLE UNDER ANY CIRCUMSTANCES: (a) FOR ANY INCIDENTAL, CONSEQUENTIAL OR SPECIAL DAMAGES (INCLUDING, WITHOUT LIMITATION, ANY LOST PROFITS OR LABOR COSTS) ARISING FROM OR RELATING TO THE PRODUCTS OR THEIR SALE, USE OR INSTALLATION; (b) FOR DAMAGES TO PROPERTY (OTHER THAN THE PRODUCTS PURCHASED FROM SELLER); (c) FROM ANY BREACH OF ITS WARRANTY OR ANY OTHER OBLIGATIONS TO BUYER; OR (d) FOR ANY OTHER CAUSE WHATSOEVER, WHETHER BASED ON WARRANTY (EXPRESSED OR IMPLIED) OR OTHERWISE BASED ON CONTRACT, OR ON TORT OR OTHER THEORY OF LIABILITY, AND REGARDLESS OF ANY ADVICE OR REPRESENTATIONS (WHETHER OR NOT IN WRITING) THAT MAY HAVE BEEN RENDERED BY SELLER CONCERNING THE DESIGN, MANUFACTURE, SALE, USE OR INSTALLATION OF THE PRODUCTS.

**14. INFRINGEMENT.** Seller at its expense will defend and hold Purchaser harmless from and against all damages, costs and expenses arising from any valid claim of infringement by a third party with respect to any patent or other intellectual property rights (collectively, the "Intellectual Property Rights") caused by Products originally manufactured by Seller, provided Purchaser (a) has not modified such Products, (b) gives Seller immediate notice in writing of any claim or commencement or threat of suit, and (c) permits Seller to defend or settle the same, and gives all immediate information, assistance and authority to enable Seller to do so. In the event any such originally manufactured Products are held to infringe an Intellectual Property Right and if Purchaser's use thereof is enjoined, Seller will, at its expense and option: (1) obtain for Purchaser the right to continue using the Products, (2) supply non-infringing Products, (3) modify the Products so that they become non-infringing, or (4) refund the then market value of such Products. In no event shall Seller's liability exceed the sale price of the infringing Products. THE FOREGOING REPRESENTS SELLER'S ENTIRE AND EXCLUSIVE OBLIGATION WITH RESPECT TO ANY CHARGE OF INFRINGEMENT OF ANY INTELLECTUAL PROPERTY RIGHT AND IS IN LIEU OF ANY STATUTORY WARRANTY RELATING TO INFRINGEMENT. Notwithstanding the foregoing, Seller shall have no liability as to any Products or parts thereof that are manufactured or modified by Purchaser or a third party, or that are manufactured or modified by Seller in accordance with Purchaser's specifications. Purchaser will defend and hold Seller harmless from and against all damages, costs and expenses whatsoever arising from any claim for infringement of any Intellectual Property Rights relating to Products that have been manufactured or modified by Seller according to specifications provided by Purchaser.

**15. CERTAIN LAWS.** Seller will comply with the applicable requirements of the Fair Labor Standards Act of 1938, as amended, Executive Order 11246, and THE rules, regulations and orders of the Secretary of Labor relating thereto.

**16. PERIOD FOR ACCEPTING QUOTATIONS.** Unless accepted without modification within thirty (30) days of issuance, or prior to withdrawal by Seller if earlier, all quotations automatically expire at the end of such thirty (30) day period.

# Terms and Conditions

# Ampco Pumps Company

**17. PROVISIONS FOR INTERNATIONAL TRANSACTIONS.** The following provisions shall apply if the Products are to be shipped to Purchaser at a location outside the United States, and apply regardless of other provisions set forth in these Terms and Conditions:

(a) The 1980 United Nations Convention on Contracts for the International Sale of Products shall not apply.

(b) Except as otherwise provided expressly stated in the agreement, terms of delivery are Ex-Works (within the meaning of INCOTERMS 2000) and all customs fees, import duties, cargo insurance, taxes and other charges imposed on or relating to the purchase or sale of the Products shall be paid by Purchaser in addition to the stated price.

(c) Except as otherwise provided expressly stated elsewhere in the agreement, payment shall be made by issuance to Seller of an irrevocable letter of credit which (i) is issued and confirmed by a U.S. bank acceptable to Seller, (ii) is governed by the Uniform Customs and Practice for Documentary Credits (UCP 600) and otherwise acceptable in form and substance to Seller, and (iii) provides for payment to Seller of the purchase price in U.S. dollars upon presentation by Seller of Seller's certification and/or such other documents as shall be required by the letter of credit. All banking and other charges for such letter of credit shall be for the account of Purchaser.

(d) Prices include Seller's standard commercial export packaging which may vary depending on whether shipment is made by air, land or sea. Except as otherwise provided expressly stated in the agreement, Purchaser will bear any additional expenses required to satisfy Purchaser's packaging requirements. Packages will be marked in accordance with Purchaser's instructions, if any. Seller shall furnish packing lists and such other information as may be necessary to enable Purchaser's agent to prepare documents required for export shipment.

(e) All shipments hereunder are subject to compliance with the U.S. Export Administration Act, as amended, regulations thereunder and all other U.S. laws and regulations concerning exports. Purchaser shall comply with all such laws and regulations concerning the use, disposition, re-export and sale of the Products provided hereunder.

**18. GENERAL.** No modification or waiver of the agreement or any of its provisions is valid unless expressly agreed to by Seller in writing, and no waiver by Seller of any default under the agreement is a waiver of any other or subsequent default. The unenforceability or invalidity of one or more of the provisions of the agreement will not affect the enforceability or validity of any other provision of the agreement. Purchaser may not assign any of its rights, duties or obligations under the agreement without Seller's prior written consent and any attempted assignment without such consent, even if by operation of law, will be void. The agreement is governed by and shall be construed in accordance with the laws of the State of Wisconsin, including the Uniform Commercial Code as enacted by such state, without giving effect to its conflict of laws principles.

# Return Policy

# Ampco Pumps Company

This policy is intended for returns that are not covered by product warranty, i.e. wrong pump or part was ordered, customer canceled order, etc. Before returning any product, contact us for a Returned Material Authorization Number (RMA#). This will eliminate confusion when the parts are received and facilitate processing the return. No action will be taken on returned parts without an RMA.

<u>Type of Return</u>	<u>Restocking Charge</u>
Standard pump with a replacement order	10%
Standard pump without a replacement order	15%
Standard parts with a replacement order	5%
Standard parts without a replacement order	10%

Additional restocking charges may be assessed for any of the following circumstances.

1. Special order motors and seals are not returnable unless we have a use for them. Credit will be determined on a case-by-case basis.
2. Impellers that are trimmed to a diameter that we don't regularly use are not returnable. Credit will be determined on a case-by-case basis.
3. Used seals and motors are not returnable.

## Credits

Credit will be issued only after parts are returned and inspected. Customer is responsible for packaging parts so they are returned in "as new" condition. Any labor required by Ampco to return the parts to "as new" condition will be deducted from the credit.





**Ampco Pumps Company**  
**2045 W. Mill Road**  
**Glendale, WI 53209**  
**Phone: (800) 737-8671 or (414) 643-1852**  
**Fax: (414) 643-4452**  
**Email: [ampcocs@ampcopumps.com](mailto:ampcocs@ampcopumps.com)**

For additional information on the IC+ series and other Ampco Pumps products, please visit our website: [www.ampcopumps.com](http://www.ampcopumps.com)